

2021 Investor & Analyst Day

Empowering Innovation & Delivering Stakeholder Results
November 8th, 2021

2021
Microchip's Investor and Analyst Day

Safe Harbor

Forward Looking Statement Safe Harbor. During the course of this presentation, we will make projections or other forward-looking statements regarding the future financial performance of the company or future events, including our vision, strategy, growth, market trends, expected revenue from industry megatrends, market size, share dilution from convertible debt repurchases, Microchip 3.0 and the financials targets related thereto, our long-term financial model, our capital allocation strategy, estimated dividend payments, growth strategy, capacity growth plans and targets and inventory targets. These forward-looking statements are made pursuant to the safe harbor provisions of the Private Securities Litigation Reform Act of 1995. These statements involve risks and uncertainties that could cause our actual results to differ materially, including, but not limited to: any continued economic uncertainty due to the impact of the COVID-19 pandemic, actions taken or which may be taken by the Biden administration or the U.S. Congress, monetary policy, political, geopolitical, trade or other issues in the U.S. or internationally, any further unexpected fluctuations or weakness in the U.S. and global economies (including China), changes in demand or market acceptance of our products and the products of our customers and our ability to meet any continued increases in market demand; the impact of current and future changes in U.S. corporate tax laws (including the Tax Cuts and Jobs Act of 2017) including the impact of such tax laws on the payment of dividends, foreign currency effects on our business; the mix of inventory we hold and our ability to satisfy short-term orders from our inventory; changes in utilization of our manufacturing capacity and our ability to effectively manage and expand our production levels to meet any continued increases in market demand; competitive developments including pricing pressures; the level of orders that are received and can be shipped in a quarter; changes or fluctuations in customer order patterns and seasonality; our ability to obtain a sufficient supply of wafers from third party wafer foundries to meet our increasing needs and the cost of such wafers, our ability to obtain additional capacity from our suppliers to increase production to meet any continued increases in market demand; our ability to realize the expected benefits of our preferred supply program; our ability to successfully integrate the operations and employees, retain key employees and customers and otherwise realize the expected synergies and benefits of our acquisitions; the impact of any future significant acquisitions that we may make; the costs and outcome of any current or future litigation or other matters involving our Microsemi acquisition, the Microsemi business, intellectual property, customers, or other issues; the costs and outcome of any current or future tax audit or investigation regarding our business or the business of Microsemi, our actual average stock price in future quarters and the impact such price will have on our share count; fluctuations in our stock price and trading volume which could impact the number of shares we acquire under our share repurchase program and the timing of such repurchases; disruptions in our business or the businesses of our customers or suppliers due to natural disasters (including any floods in Thailand), terrorist activity, armed conflict, war, worldwide oil prices and supply, public health concerns (including the COVID-19 pandemic) or disruptions in the transportation system; and general economic, industry or political conditions in the United States or internationally.

For a detailed discussion of these and other risk factors, please refer to Microchip's filings on Forms 10-K and 10-Q. You can obtain copies of Forms 10-K and 10-Q and other relevant documents for free at Microchip's website (www.microchip.com) or the SEC's website (www.sec.gov) or from commercial document retrieval services. Stockholders of Microchip are cautioned not to place undue reliance on our forward-looking statements, which speak only as of the date such statements are made. Microchip does not undertake any obligation to publicly update any forward-looking statements to reflect events, circumstances or new information after the date of this presentation, or to reflect the occurrence of unanticipated events.

Use of Non-GAAP Financial Measures: In this presentation, we have included certain non-GAAP financial information, including adjusted EBITDA, non-GAAP gross profit, non-GAAP operating profit and free cash flow. Our non-GAAP results exclude, where applicable, the effect of share-based compensation, COVID-19 shelter-in-place restrictions on manufacturing activities, expenses related to our acquisition activities (including intangible asset amortization, inventory valuation costs, excess capacity charges to normalize acquired inventory levels, severance and other restructuring costs, and legal and other general and administrative expenses associated with acquisitions including legal fees and expenses for litigation and investigations related to our Microsemi acquisition), professional services associated with certain legal matters, IT security remediation costs, non-cash interest expense on our convertible debentures, losses on the settlement of debt, and gains and losses related to available-for-sale investments. Our determination of our non-GAAP measures might not be the same as similarly titled measures used by other companies, and it should not be construed as a substitute for amounts determined in accordance with GAAP. There are limitations associated with using non-GAAP measures, including that they exclude financial information that some may consider important in evaluating our performance. Management compensates for this by presenting information on both a GAAP and non-GAAP basis for investors and providing reconciliations of the GAAP and non-GAAP results. Non-GAAP measures should not be considered in isolation or as an alternative to net income, cash from operations or other measures of profitability, liquidity or performance under GAAP. These non-GAAP and GAAP results and reconciliations are included in the appendix to this presentation. Certain supplemental information and reconciliations are available on our website at www.microchip.com/investors under the heading "Supplemental Financial Information".

Agenda

- **Overview and Value Proposition**
- **Capital Return Strategy**
- **Business Growth Strategy**
- **Enabling Our Business Growth**
- **Summary**
- **Q&A**



Overview and Value Proposition

Eric Bjornholt, SVP & CFO
Ganesh Moorthy, President & CEO

2021
Microchip's Investor and Analyst Day

Corporate Overview

Leading Total Systems Solutions Provider:

- High-performance standard and specialized Microcontroller, Digital Signal Controller and Microprocessor solutions
- Mixed-Signal, Analog, Interface and Security solutions
- Clock and Timing solutions
- Wireless and Wired Connectivity solutions
- FPGA solutions
- Non-volatile EEPROM and Flash Memory solutions
- Flash IP solutions



\$6.4 Billion Revenue
Run-rate for FY2022*



Headquartered near
Phoenix in Chandler, AZ

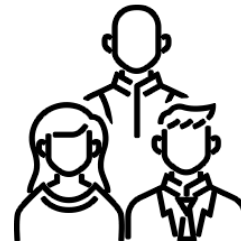

~20,000
Employees

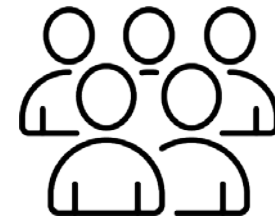

120,000+
Customers

Our Purpose

Empowering innovation which enhances the human experience by delivering smart, connected and secure technology solutions



Our Vision

*Be The Very Best Embedded Control
Solutions Company Ever*



SMART | CONNECTED | SECURE

Our Mission



*In order to contribute to the ongoing success of **customers, employees, shareholders and the communities in which we operate**, our mission is to focus resources on high value, high quality products, total system solutions, software and services, and to continuously improve all aspects of our business, **providing an industry leading return on investment***

Microchip 2.0

Sustained growth from organic efforts and acquisitions

Built company scale and **product line breadth** through acquisitions

Total System Solutions enabled by product line breadth

Continuing **market share gains** in Microcontrollers and Analog

Large exposure to **Industrial and Automotive markets**

Solutions with very **long market life**

Record gross and operating margins from scale and acquisition synergies

Debt financed acquisitions followed by **substantial debt reduction**

Consistent capital return through steady dividends

Providing Total System Solutions

Portfolio of Hardware, Software and Services

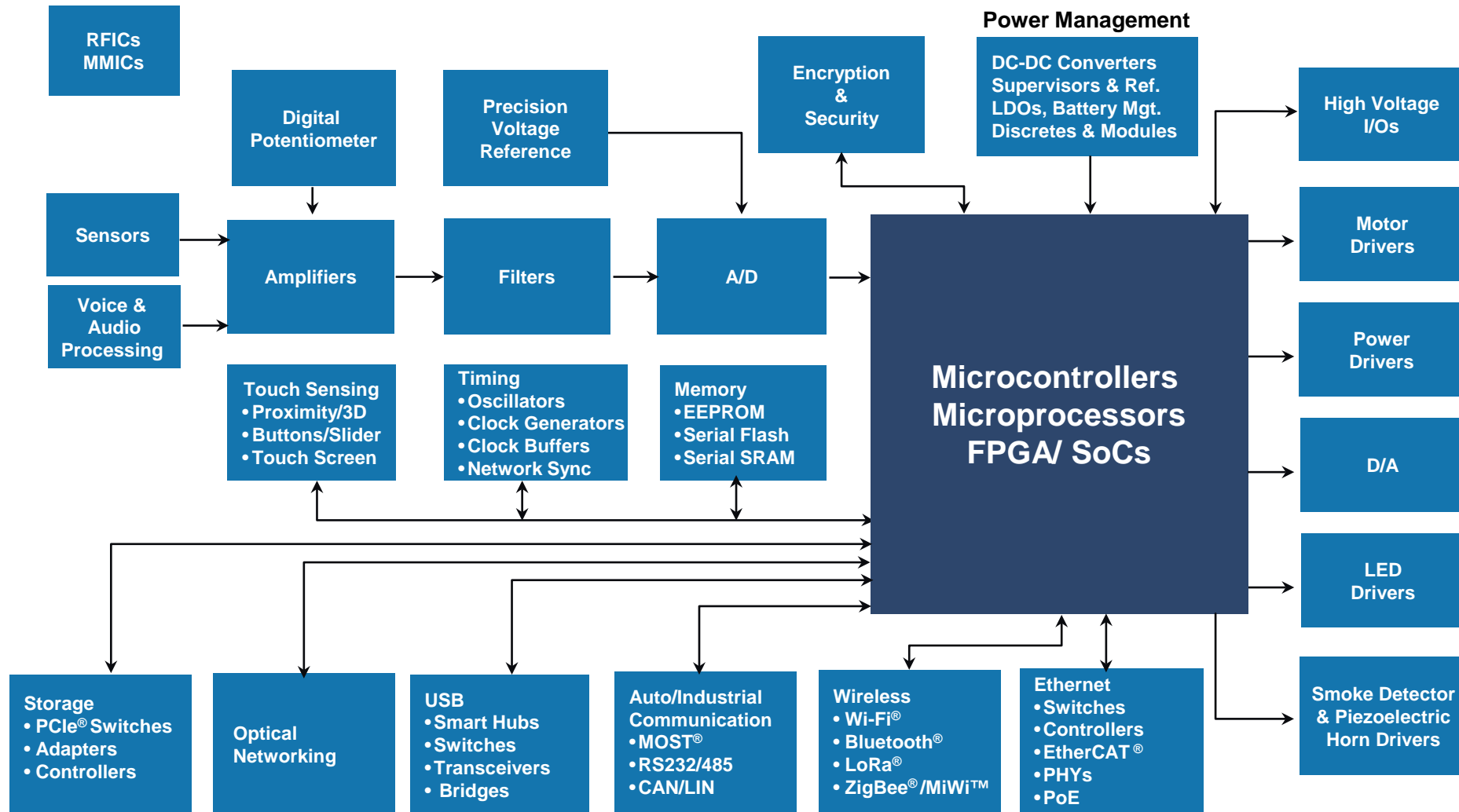

Worldwide Microcontroller Market Share

No.	1991 Rank	1996 Rank	2003 Rank	2008 Rank	2009 Rank	2014 Rank	2019 Rank	2020 Rank
1	Motorola	Motorola	Renesas	Renesas	Renesas	Renesas	Renesas	Renesas
2	Intel	NEC	Motorola	NEC	NEC	Freescale	NXP	NXP
3	Philips	Philips	NEC	Freescale	Freescale	ST-Micro	Microchip	Microchip
4	Mitsubishi	Hitachi	Matsushita	Infineon	Samsung	Microchip	ST-Micro	ST-Micro
5	NEC	Mitsubishi	Infineon	Samsung	Microchip	NXP	Infineon	Infineon
6	Hitachi	Toshiba	Fujitsu	Microchip	TI	TI	TI	TI
7	Toshiba	Matsushita	Toshiba	ST-Micro	Infineon	Infineon	Others	Others
8	Siemens	SGS-Thom	Microchip	TI	St-Micro	Atmel		
9	TI	Intel	Samsung	Fujitsu	Fujitsu	Spansion		
10	Matsushita	Microchip	ST-Micro	NXP	NXP	Samsung		
23		Microchip						

Annotations: A red bracket indicates a 9.0% change between 2019 and 2020 for the top 3 companies. A blue bracket indicates a 7.5% change between 2014 and 2019 for the top 3 companies. A larger blue bracket indicates a 3.6% change between 2009 and 2020 for the top 3 companies.

Analog Revenue Growth

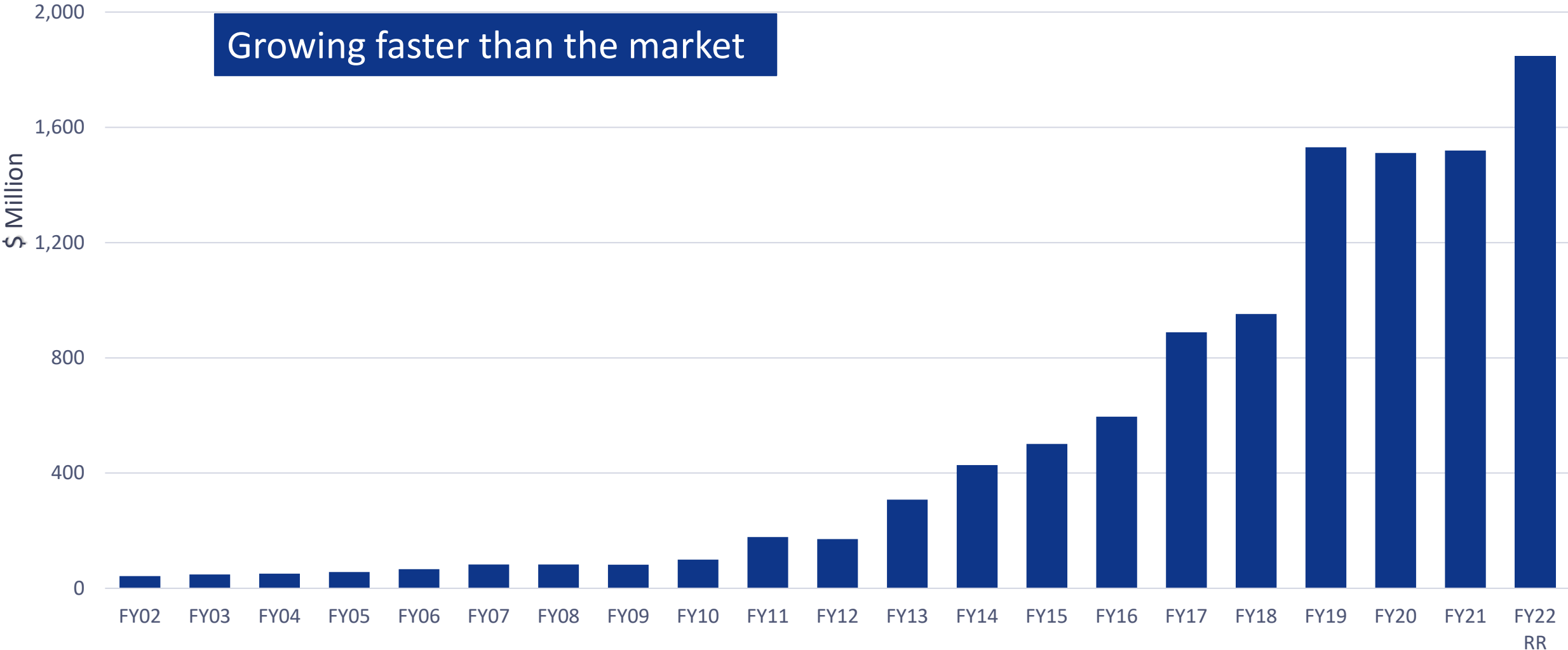

Revenue By End Market

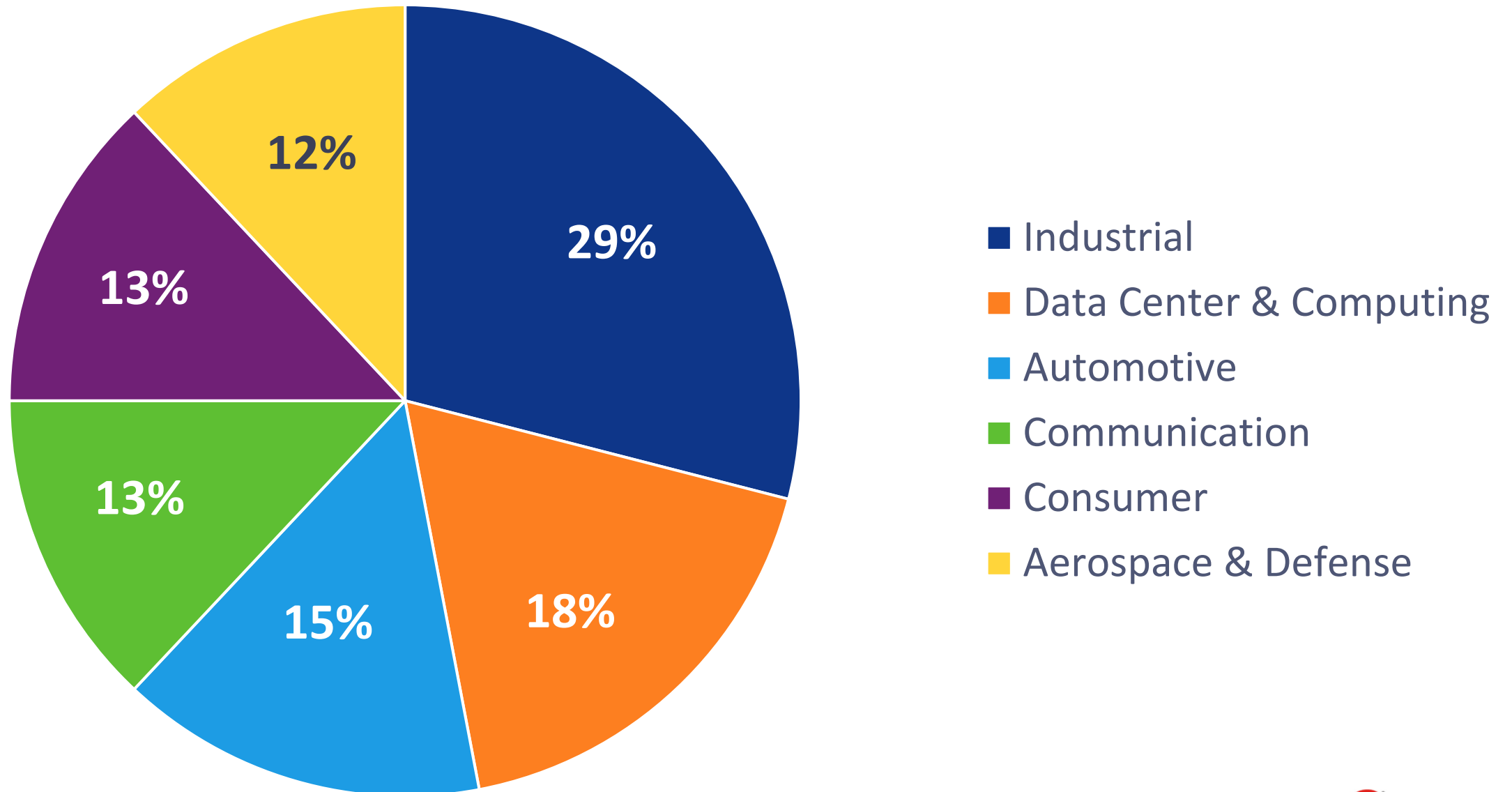

Our Market Megatrends



Revenue By Megatrend

Megatrends currently represent ~1/3 of total revenue

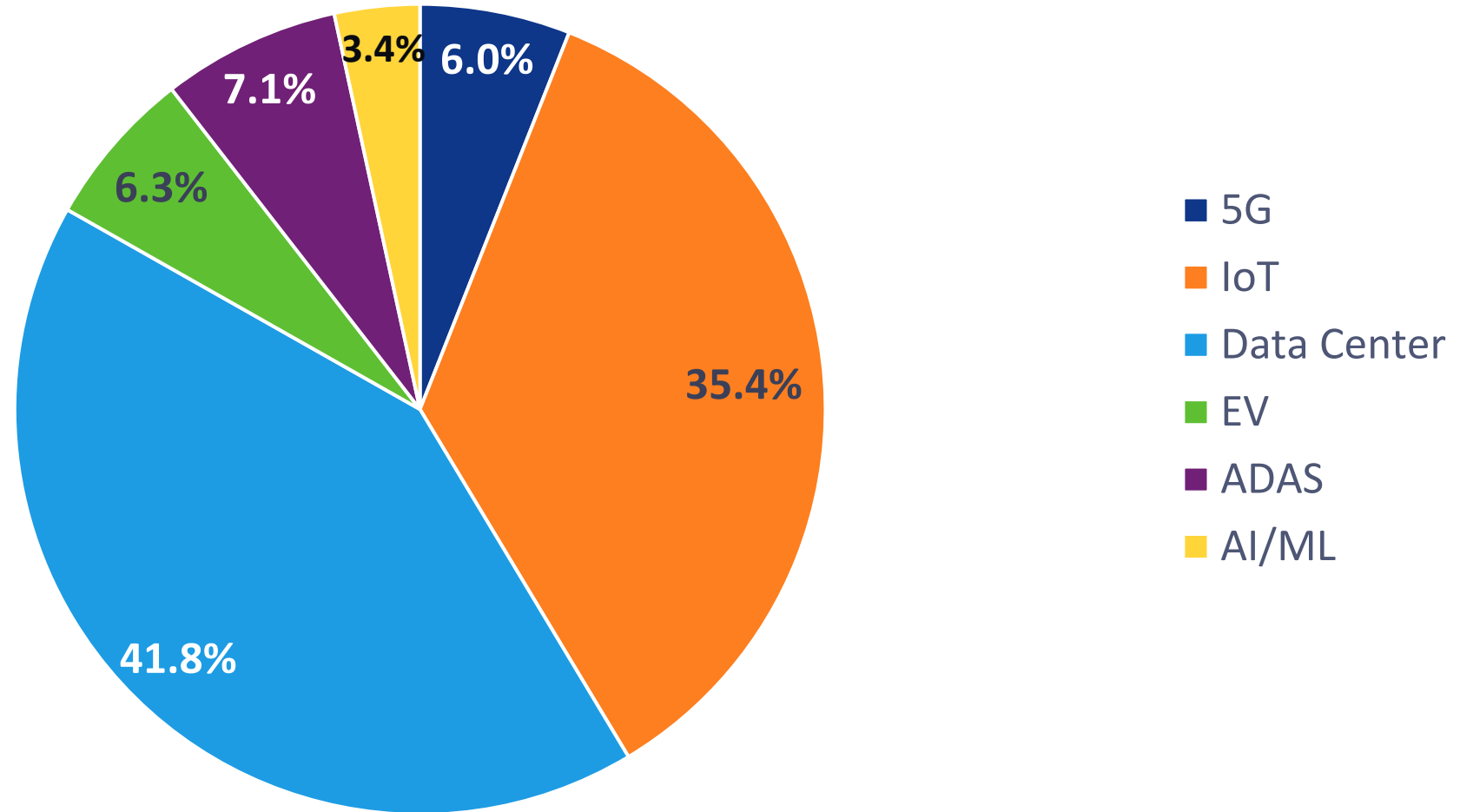

We expect our revenue from Megatrends to grow at ~2X Microchip's growth rate

Our Broad Market Business

Currently represents ~2/3 of total revenue

Highly fragmented business –
fragmentation is our friend!

Solid business foundation that is
durable and defensible

Continuously elbows out
into adjacent spaces

Identifies new and emerging
applications and markets

Growing SAM

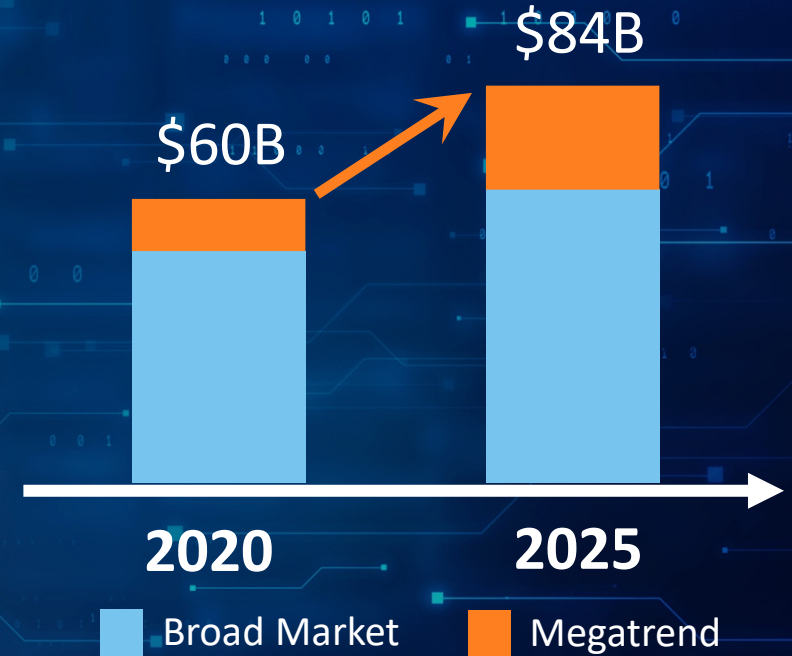

Broad Market + Megatrend CAGR: 7%
Megatrend CAGR: 14.3%

Net Sales Growth

124 consecutive quarters of Non-GAAP profitability!

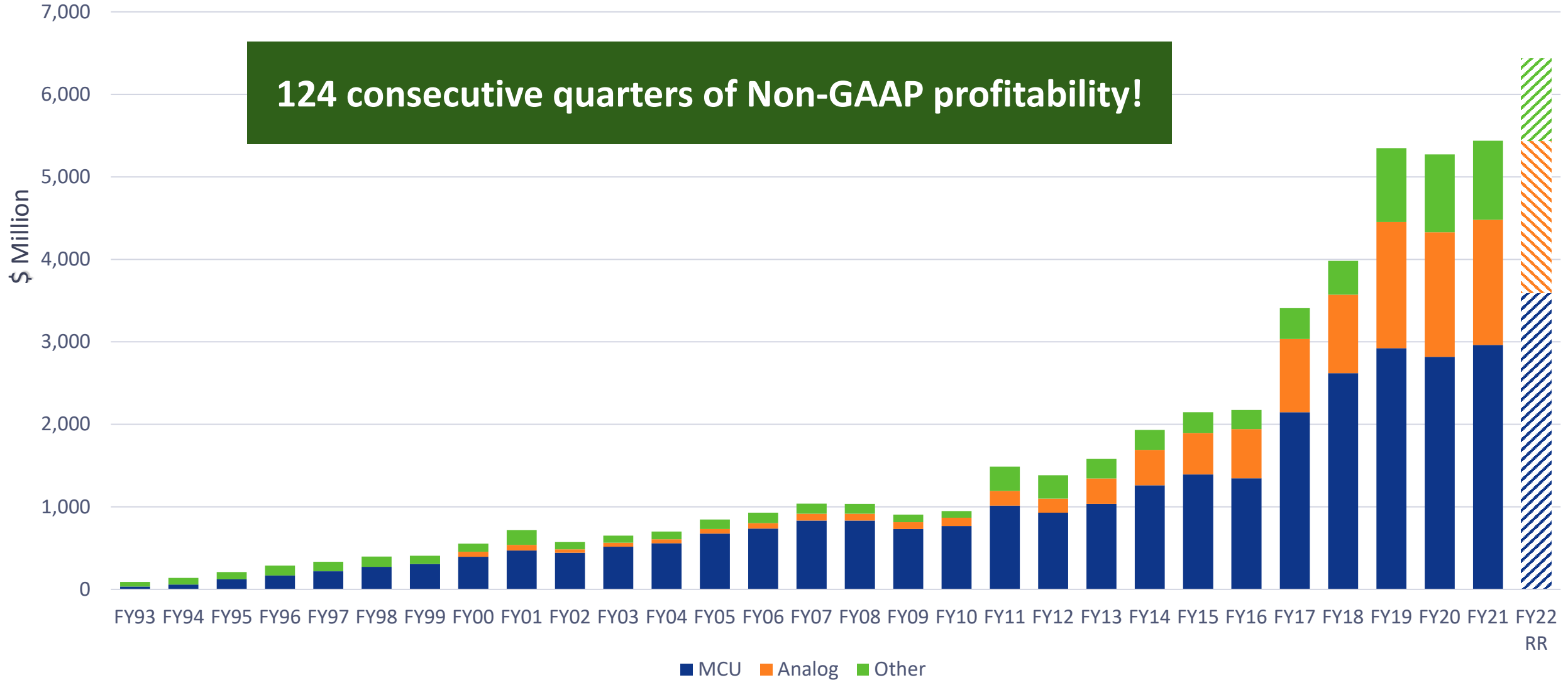

Non-GAAP Gross Profit

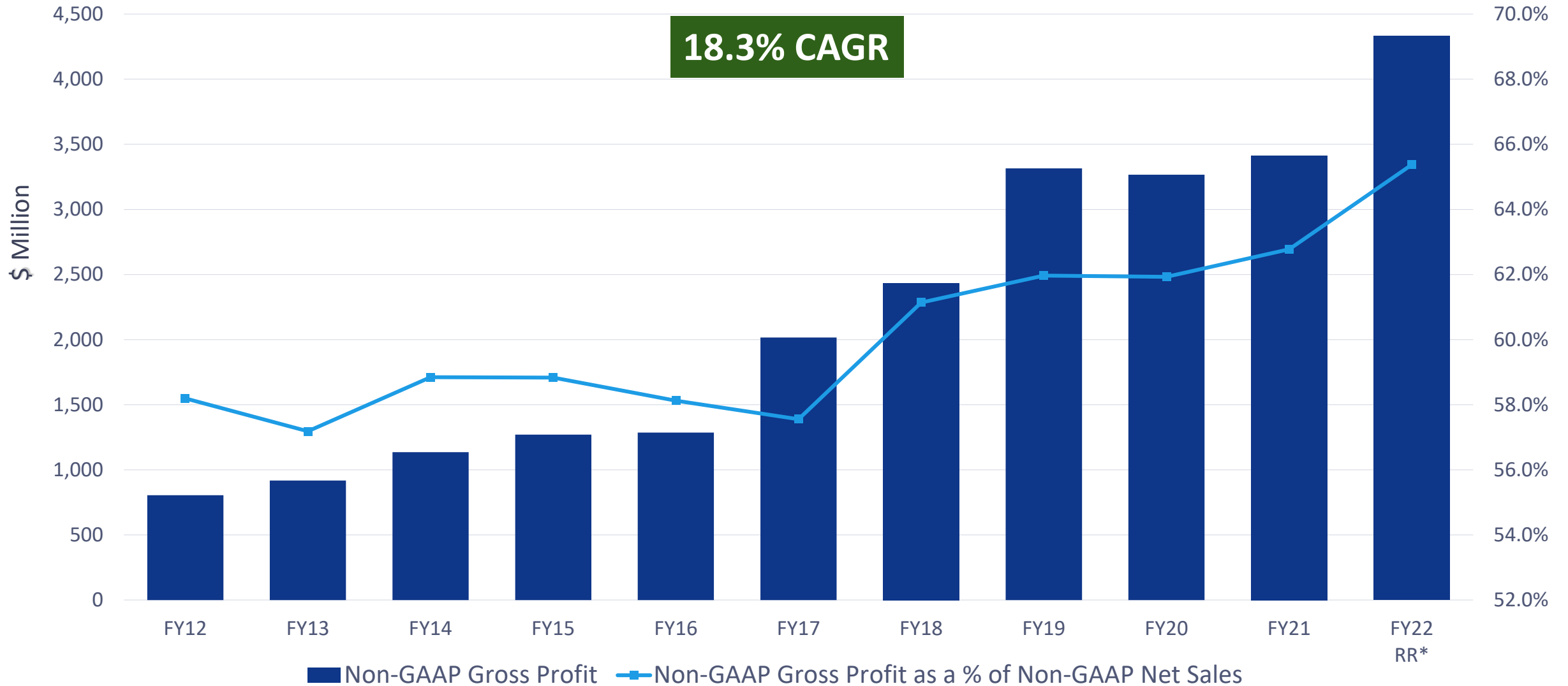

Non-GAAP Operating Income

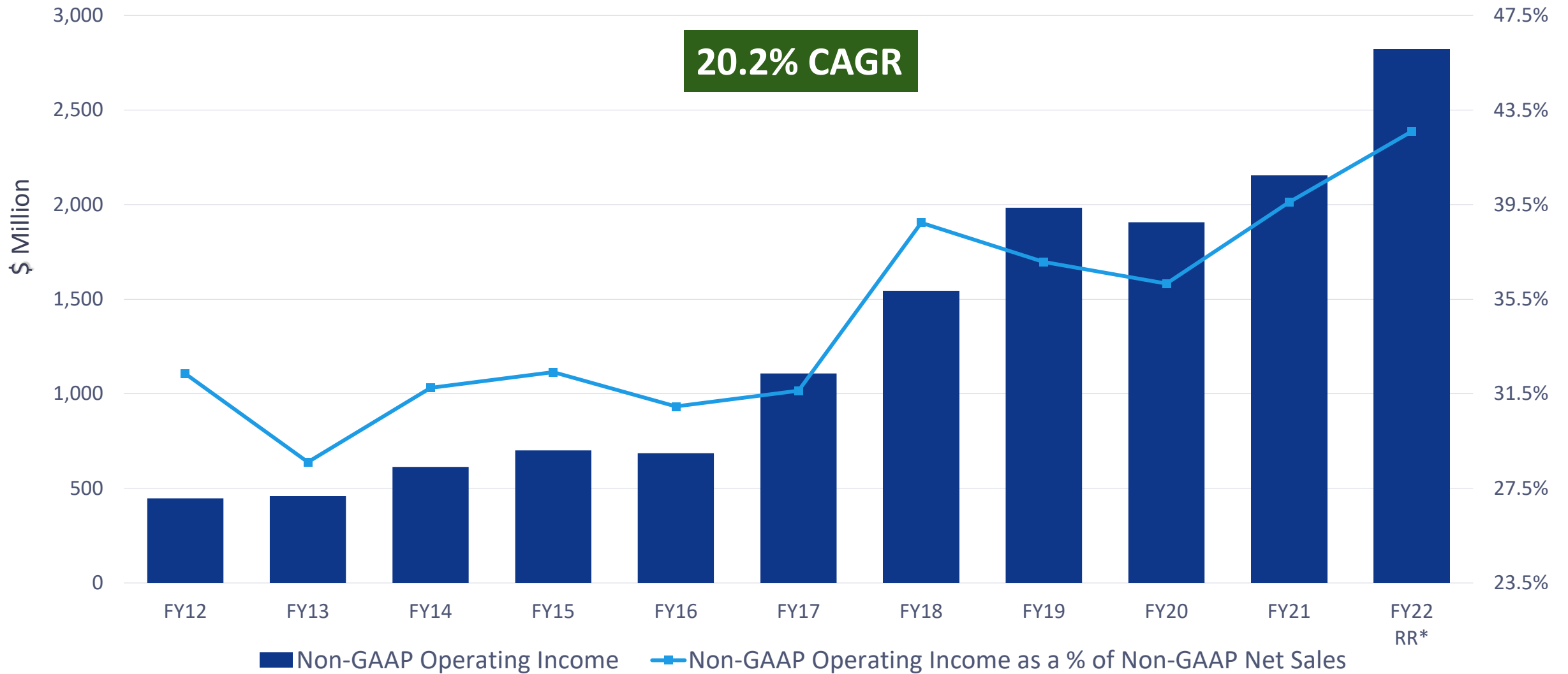

Adjusted EBITDA

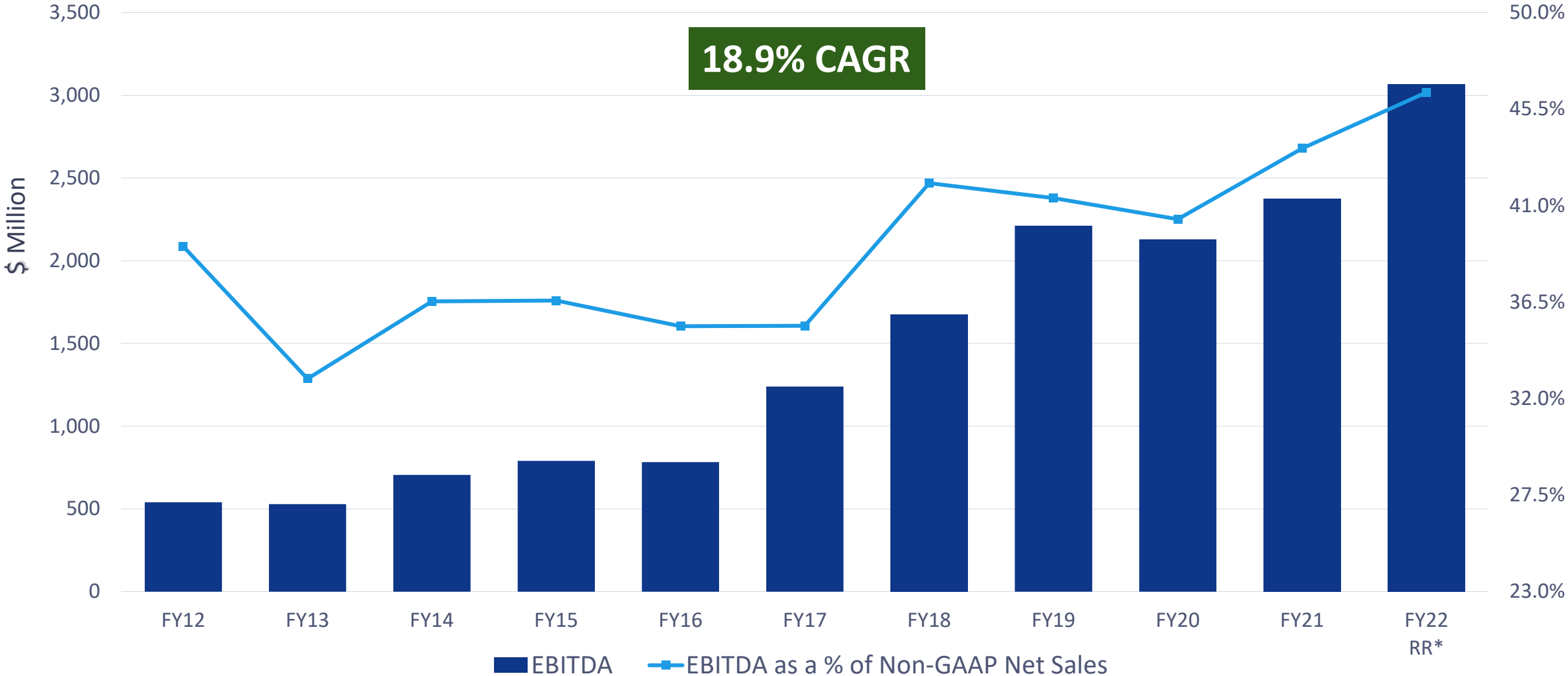

21 * Run rate for FY22 represents (actual results for the first two quarters plus management estimate based on our guidance for Q3)/3 * 4



Free Cash Flow

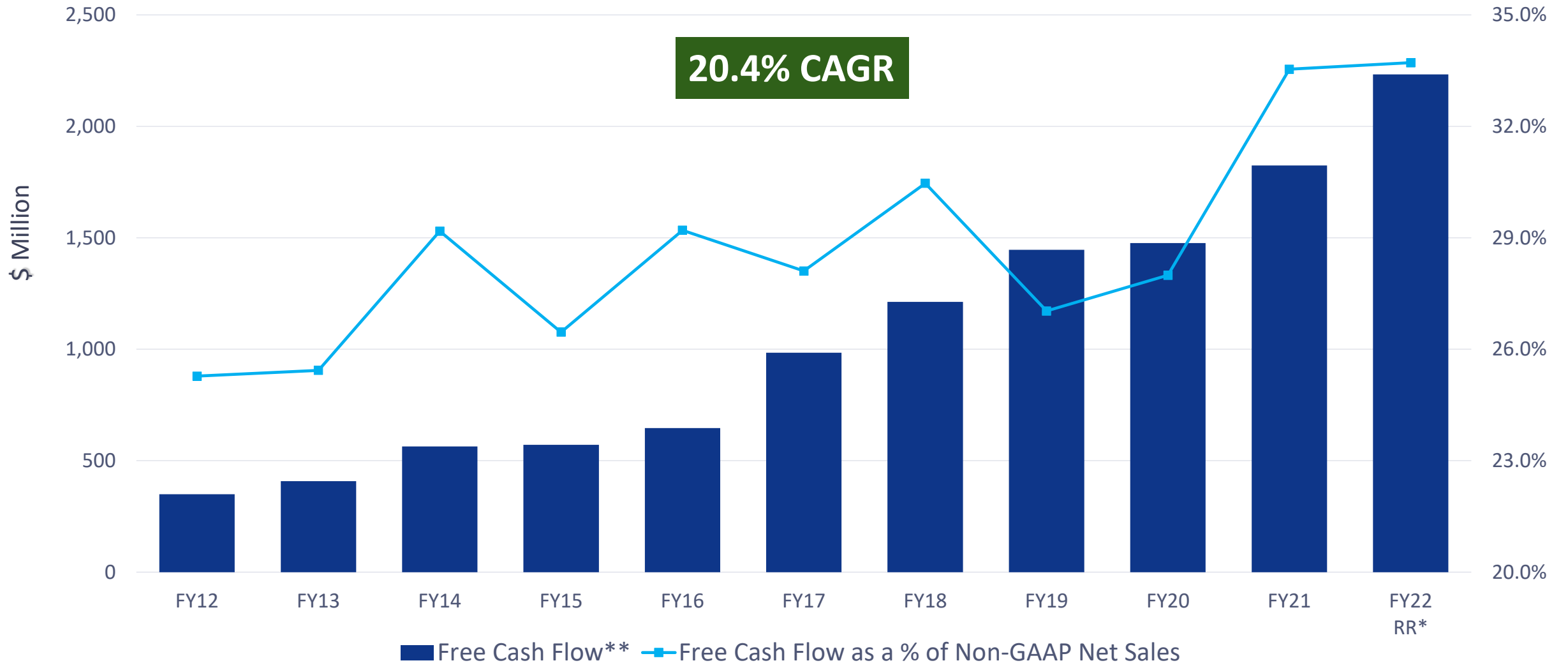

* Run rate for FY22 represents (actual results for the first two quarters plus management estimate based on our guidance for Q3)/3 * 4

** Free Cash Flow represents cash provided by operating activities less capital expenditures

Strengthening Our Balance Sheet

Over the last full 13 quarters since Microsemi acquisition closed (May 2018), we have paid down \$4.41 billion of debt

Repurchased \$4.15 billion of deep in the money convertible bonds

In December 2020, refinanced \$1.4 billion of Term Loan B with a three-year secured bond with a 0.972% interest rate

In May 2021, refinanced a \$1.0 billion three-year senior secured bond with a 3.922% rate with a new three-year senior secured bond with a 0.983% interest rate

Net Debt, Adjusted EBITDA & Net Leverage

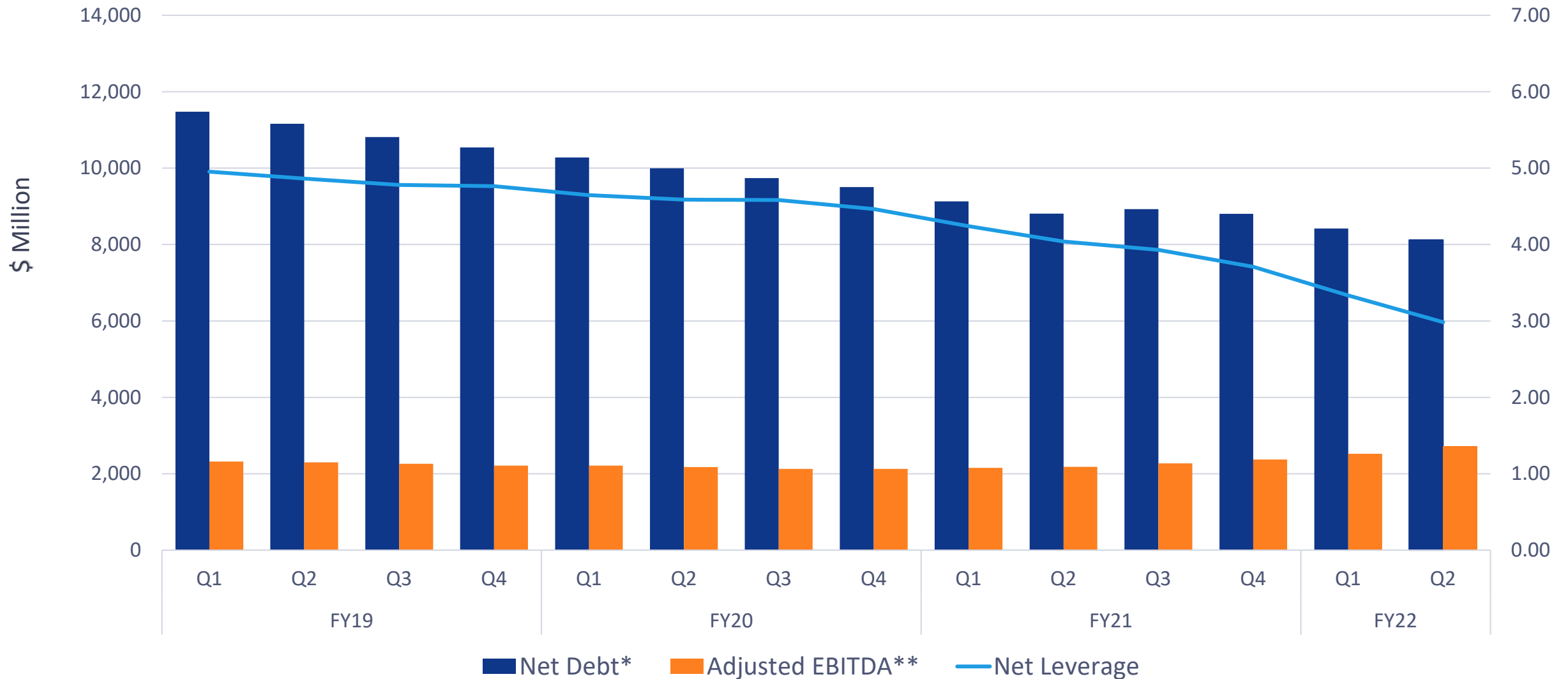

* Net debt is defined as total debt less cash/investments less 2037 convertible debentures

**Adjusted EBITDA is as defined in the Company's Amended and Restated Credit Agreement dated as of March 21, 2020

Total Debt



*Q3 FY22 represents management estimate based on our guidance for Q3 and assumes no stock buyback during the quarter



Convertible Debt*

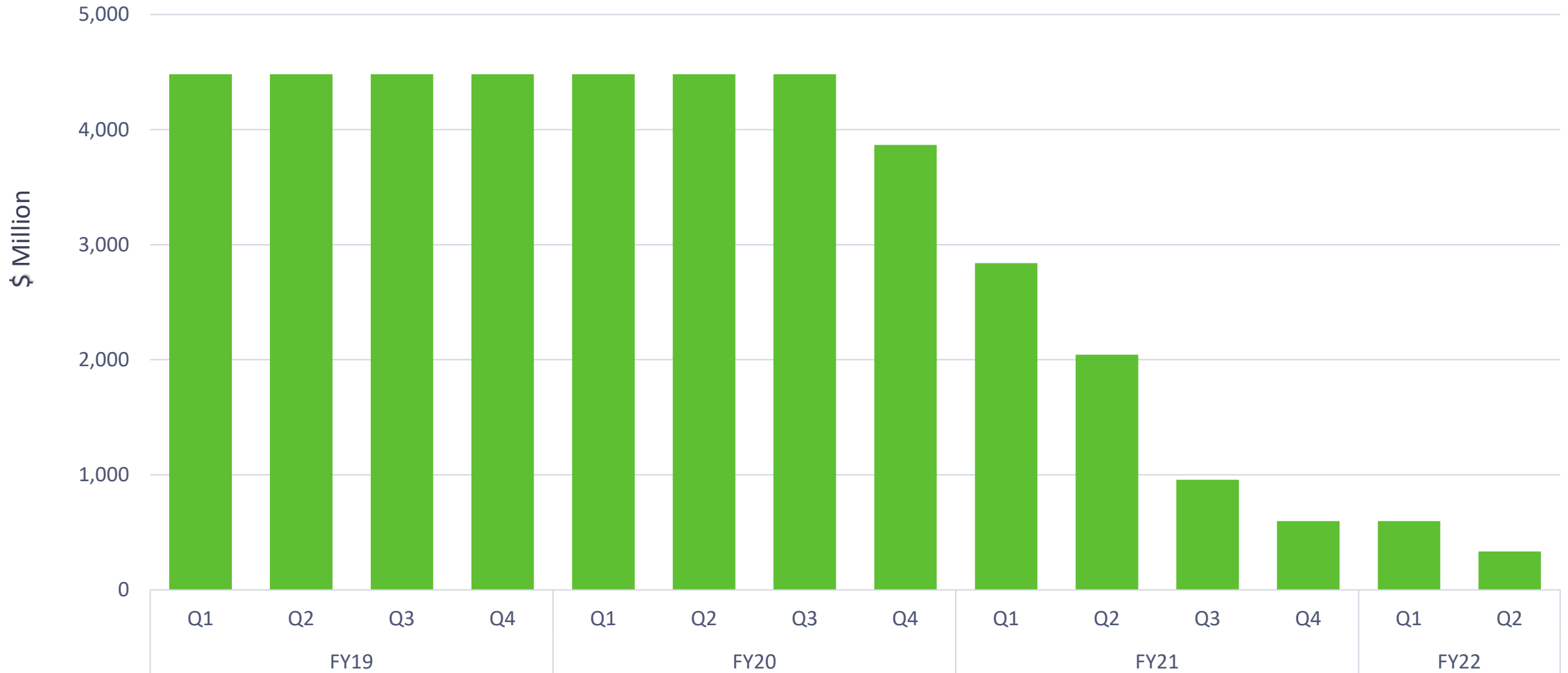

Total Convertible Debt Repurchased – Share Dilution Avoidance

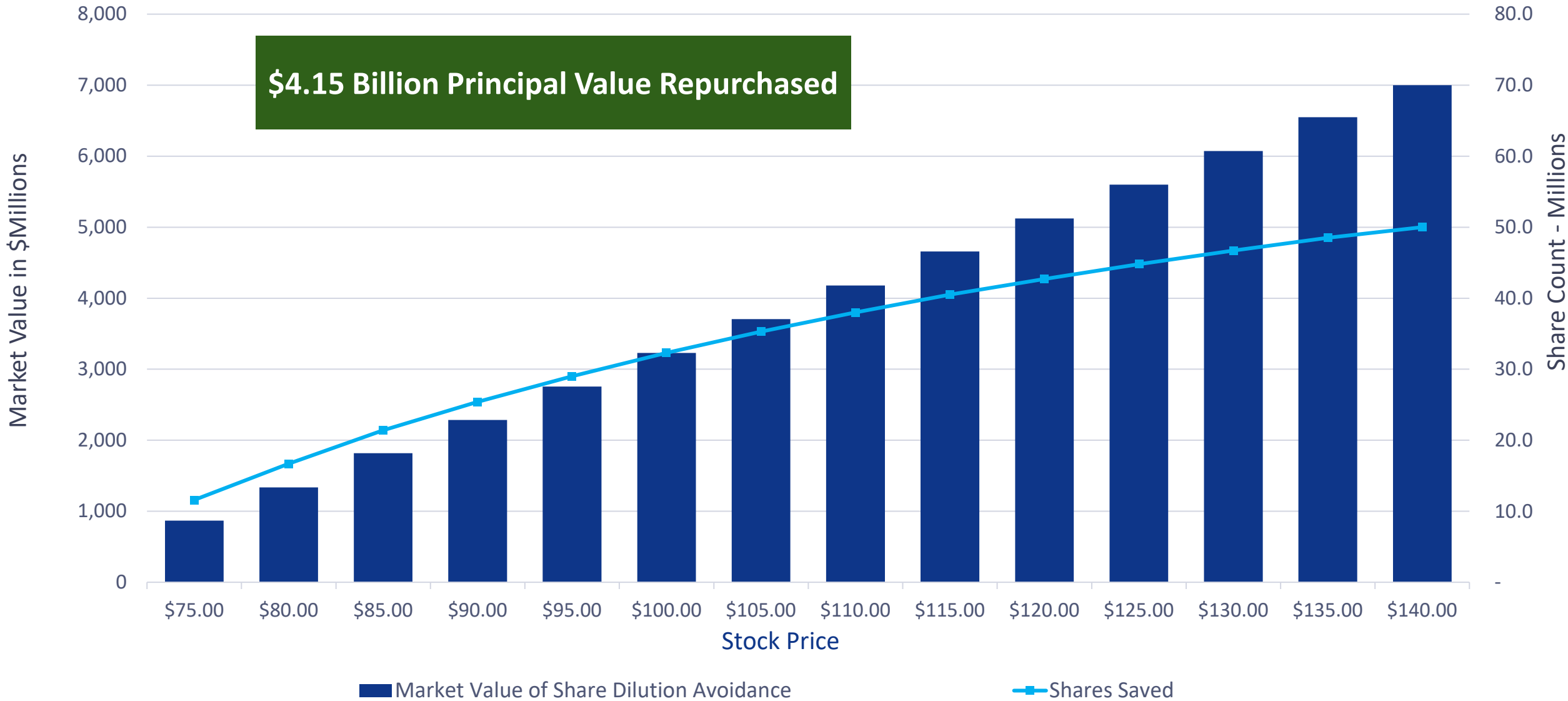

27 Note: values at maturity assume constant conversion rate from now to maturity – actual value could be significantly more dilutive upon further anti-dilution adjustments



Fixed Rate vs. Variable Rate Debt

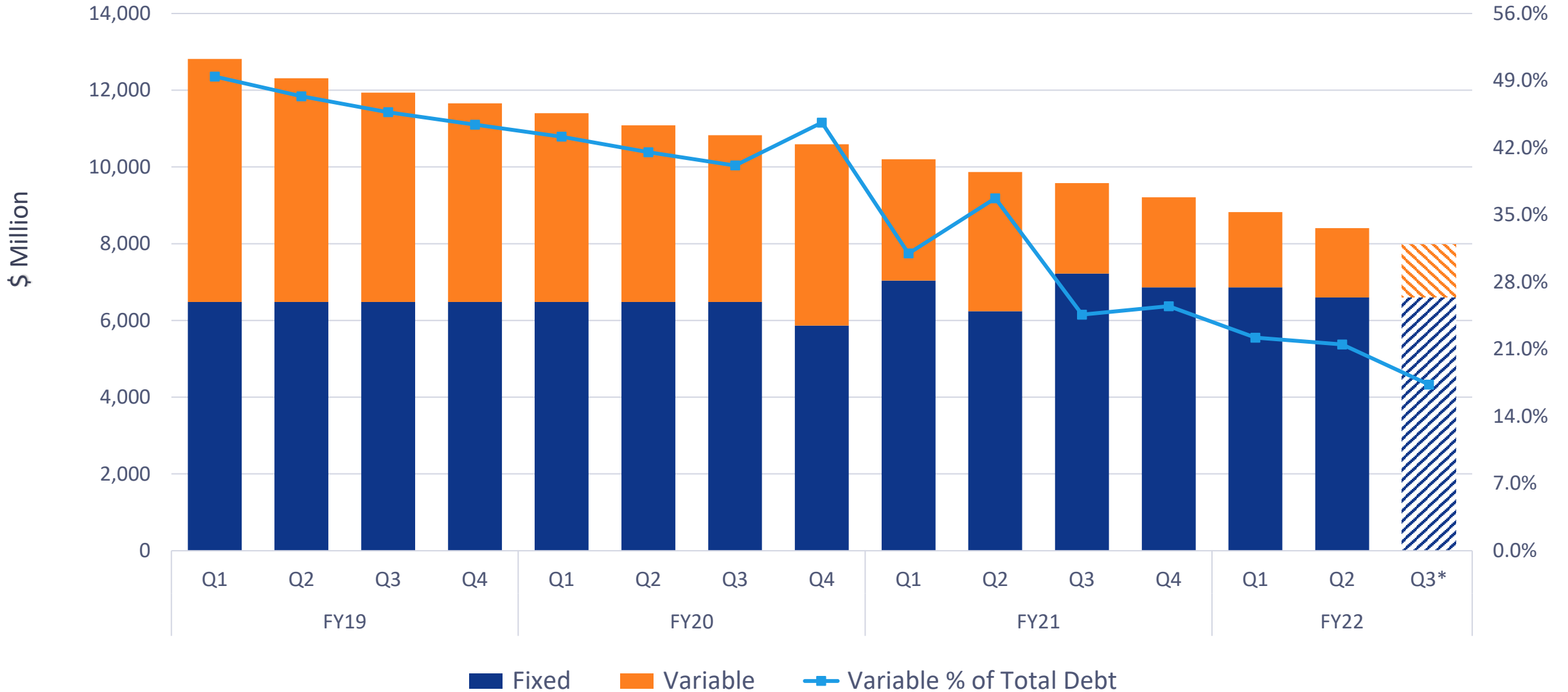

Microchip 2.0

Sustained growth from organic efforts and acquisitions

Built company scale and **product line breadth** through acquisitions

Total System Solutions enabled by product line breadth

Continuing **market share gains** in Microcontrollers and Analog

Large exposure to **Industrial and Automotive markets**

Solutions with very **long market life**

Record gross and operating margins from scale and acquisition synergies

Debt financed acquisitions followed by **substantial debt reduction**

Consistent capital return through steady dividends

Microchip 2.0 Today

Sustained growth from organic efforts and acquisitions

Built company scale and product line breadth through acquisitions

Total System Solutions enabled by product line breadth

Continuing market share gains in Microcontrollers and Analog

Large exposure to Industrial and Automotive markets

Solutions with very long market life

Record gross and operating margins from scale and acquisition synergies

Debt financed acquisitions followed by substantial debt reduction

Consistent capital return through steady dividends

Microchip 3.0

Sustained growth from organic efforts focused on TSS and Megatrends

6-8% Organic Revenue CAGR;
~2X industry growth rate*

Elite long-term non-GAAP business model of
67.5% - 68.5% Gross Margin
44% - 46% Operating Margin

EBITDA Margin target of $\geq 48\%$ and FCF target of $\geq 38\%$ of revenue

Diversified end-market mix creates consistent and resilient results

Investment in inventory – 130 - 150 days over business cycles

Investment in capacity for trailing-edge technologies – capital intensity of 3% - 6% of revenue

Increase capital returned to shareholders to 50% of FCF, rising to 100% of FCF as net leverage drops to $\leq 1.5X$

Strong business foundation based on culture and sustainability

Long-Term Non-GAAP Target Model

	1H FY22 Run Rate	Long-Term Target	
Revenue	\$6.4B	6 - 8% CAGR	Grow at ~2X industry growth rate**
Gross Margin	65.0%	67.5% - 68.5%	Continued internalization, manufacturing consolidating, richer product mix and pricing discipline
Operating Expenses	22.9%	22.5% - 23.5%	Operating expense investment to drive growth and high value product mix
Operating Margin	42.1%	44% - 46%	Gross margin improvement drops to operating margin
CAPEX	5.1%	3 - 6 %	Investment in trailing edge technologies
Adjusted EBITDA Margin	45.8%	48%	
Free Cash Flow Margin	33.4%	38%	

* 1H FY22 Run Rate is based on the Company's Q1 and Q2 FY22 non-GAAP results, with revenue multiplied by 2

Capital Return Strategy







2021
Microchip's Investor and Analyst Day

Steve Sanghi, Executive Chair

Agenda

- **How We Allocate Our Capital**
- **Debt Paydown Progression**
- **Historical Dividend Growth**
- **Future Cash/Capital Return Strategy**

Disciplined Capital Allocation Strategy

	Last 10 Years	Microchip 3.0
 R&D, Sales/Marketing and other	Disciplined, strategic, and opportunistic, organic growth investments. What the P&L can afford.	Continued disciplined, strategic, and opportunistic organic growth investments. What the P&L can afford.
 Capital Expenditure	Average of about 3% to 4% of revenue.	3% to 6% of revenue to add capacity; insource manufacturing; dependable delivery and competitive lead times.
 Inventory	Target of 115 to 120 days.	Target of 130 to 150 days.
 Debt	Levered up for M&A followed by strong cash generation; actively reducing debt	Receive/maintain an IG rating. Reduce net debt to adjusted EBITDA to 1.5x.
 Dividends	With M&A a focus, slow and consistent dividend growth	Accelerating dividend growth as leverage decreases.
 Stock Buybacks	Selective and only if issued shares in an M&A transaction.	Significant once we receive IG rating. Aimed to reduce share count, improve EPS and free cash flow per share.
 Acquisitions	Serial acquirer driven by Total System Solutions (TSS) strategy to enhance shareholder value creation.	No near-term large-scale M&A. Small tuck-ins possible for IP, Technology, engineering talent, etc.

Net Debt, Adjusted EBITDA & Net Leverage

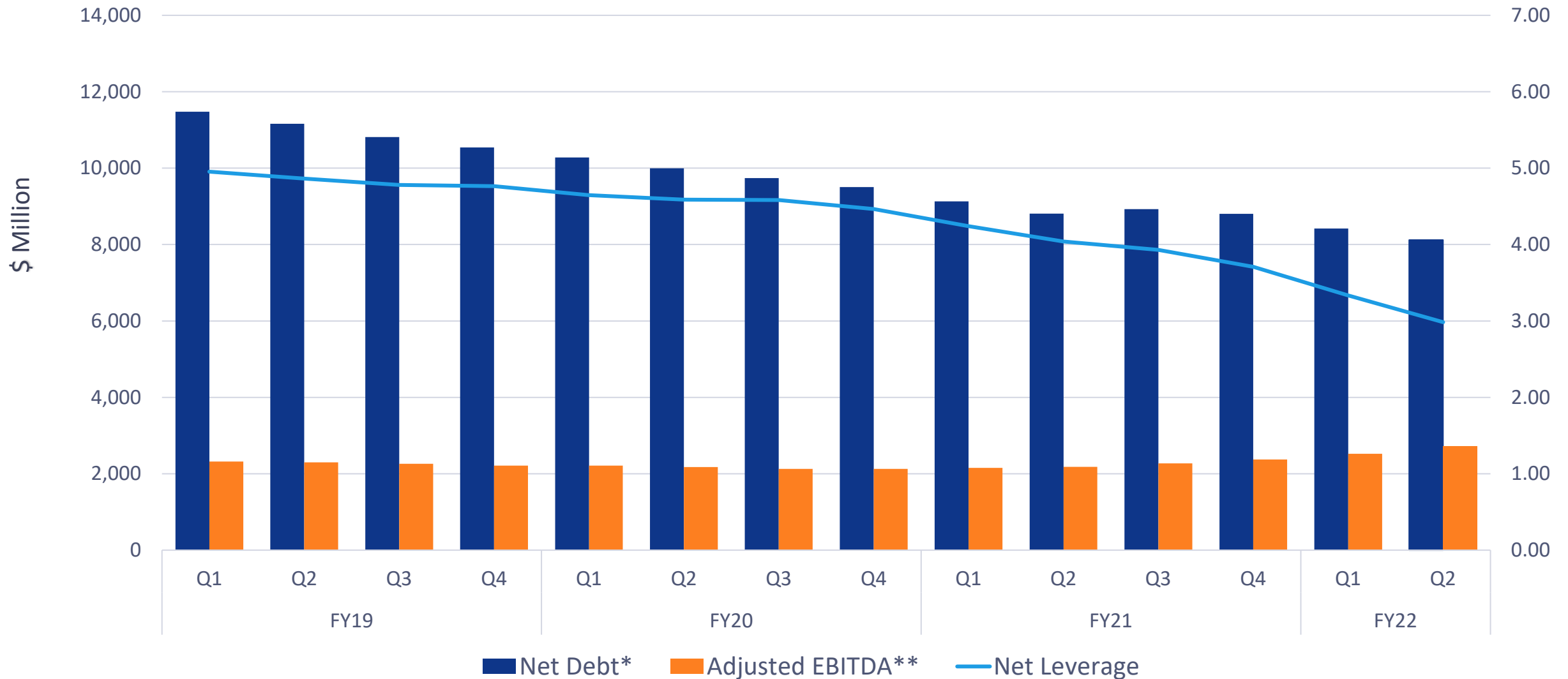

* Net debt is defined as total debt less cash/investments less 2037 convertible debentures

**Adjusted EBITDA is as defined in the Company's Amended and Restated Credit Agreement dated as of March 21, 2020

\$5.0 Billion Returned to Shareholders

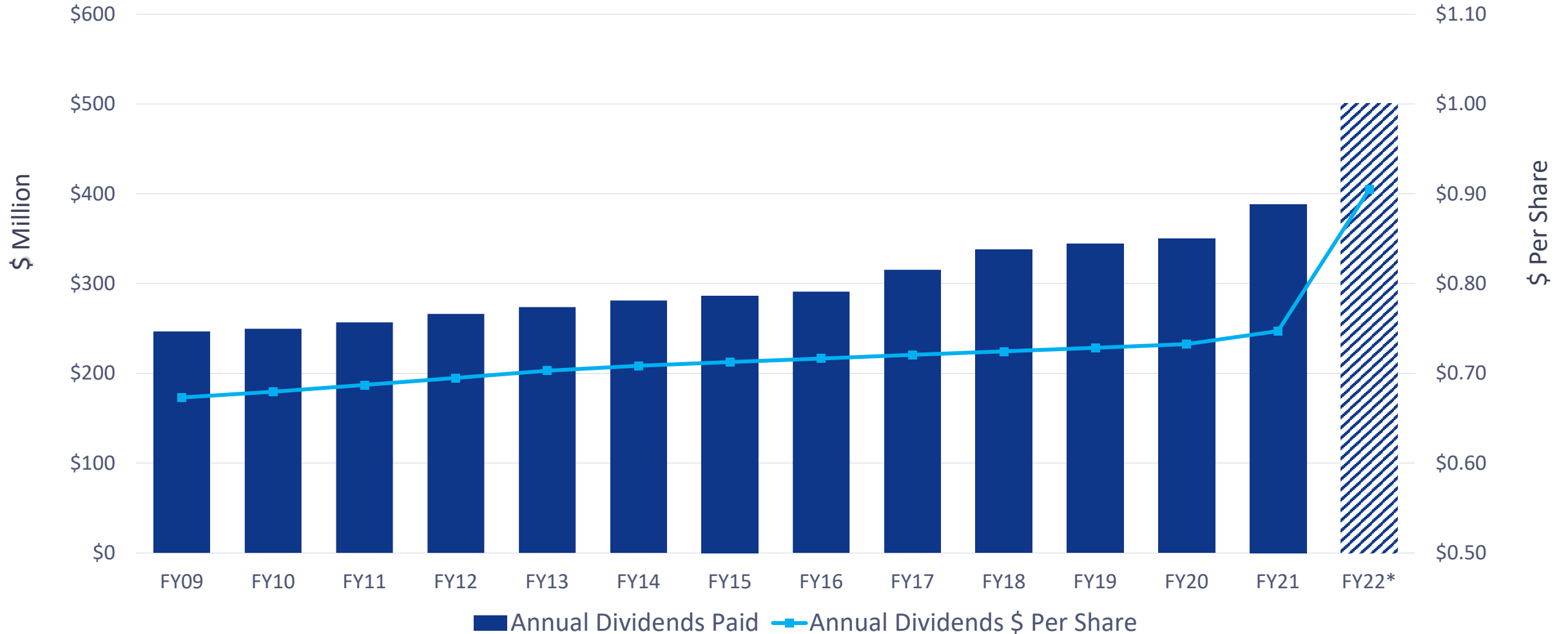

Total Convertible Debt Repurchased – Share Dilution Avoidance

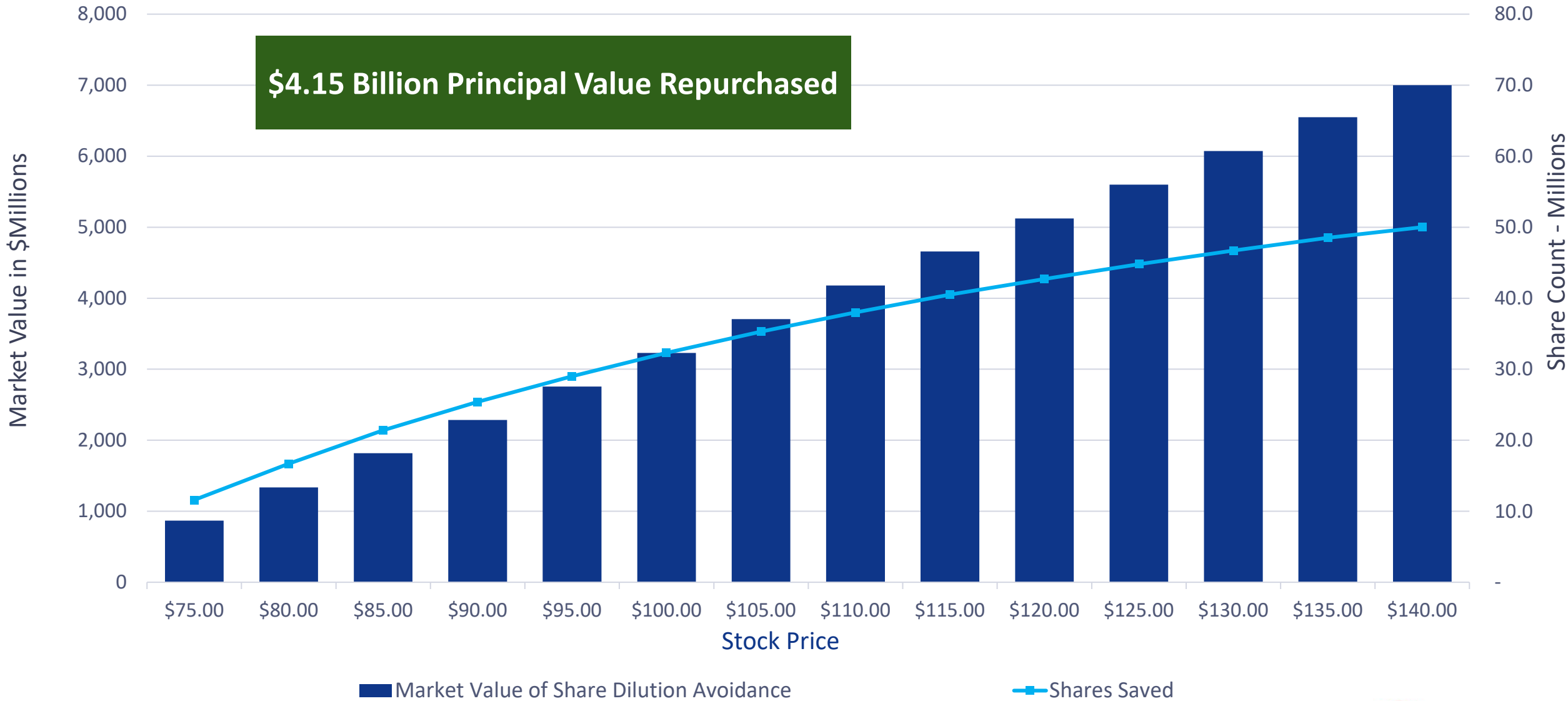

38 Note: values at maturity assume constant conversion rate from now to maturity – actual value could be significantly more dilutive upon further anti-dilution adjustments



Future Capital Return Strategy

M&A Strategy Has Achieved its Goals

In 2010, we set out to achieve the following goals:

1. Build significant scale to compete with our larger competitors
2. Strategically acquire companies that fit into our embedded control market strategy
3. Build and acquire a product portfolio that would enable us to provide a total system solution to our customers
4. Pay reasonable valuations to make acquisitions highly accretive
5. Pay cash/debt for acquisitions and use substantial profits to de-lever

Current Situation

Current annualized revenue run rate of ~\$7 billion*, we no longer have a scale disadvantage to most of our competitors.

Current valuations are not meeting our disciplined financial metrics for M&A.

There is no deal left that we must do. Remaining targets are less strategic.

Just reaching **debt leverage of 3.0**. We do not want to re-lever up.

We have a product portfolio that can provide a total system solution to our customers. There are no gaping holes.

Small tuck-in/strategic acquisitions

Shift to Capital Return Strategy

Currently Generate Approximately **\$550 million**
in Free Cash Flow (FCF) per Quarter

Trigger: Investment grade rating from both Moody's and Fitch

- Increase total cash returned to shareholders from the current ~23% of FCF to ~50% of FCF, after achieving IG rating
- Increase capital returned to shareholders to 50% of FCF, rising to 100% of FCF
 - Increase dividend at least 7% sequentially, until it gets to 50% of FCF
 - Start by implementing stock buyback for the difference between 50% of FCF less the dividend
 - Use remaining FCF to further pay down debt; achieve leverage target of $\leq 1.5X$
- Over time increase cash return to shareholders to 100% of FCF*

Increasing Dividends

Board of Directors Targeting Substantial Growth in Dividends

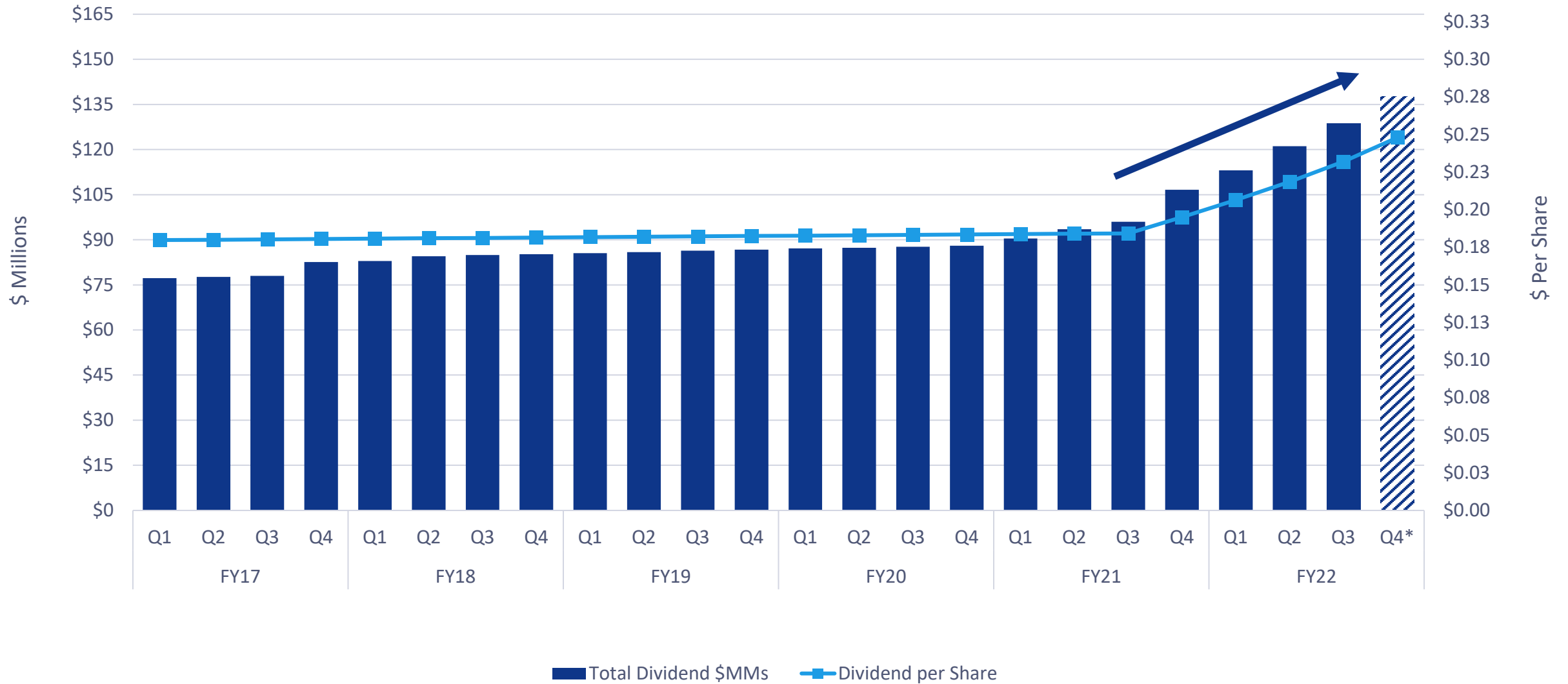

Stock Buyback

- Board authorized a new \$4 billion stock buyback on November 8th in lieu of the previous 30 million share authorization
- To be executed over time based on cash generation, leverage metrics, and market conditions.
- Contingent on achieving IG rating

Strong Capital Return Focus

Existing TSS product portfolio, deleveraging, and improved business model drives shift from M&A to capital return

Upon IG rating from Moody's and Fitch, we plan to increase the cash return from ~23% of FCF now to ~50% of FCF

- Increase quarterly dividend growth rate further
- Add a large stock buy-back component

Systematically increase cash returned to shareholders toward 100% of FCF as leverage approaches 1.5x

Growth Strategy

Total System Solutions & Megatrends

Rich Simoncic, SVP Analog Power & Interface

2021
Microchip's Investor and Analyst Day

Microchip Organic Growth Strategy

- **Focus on Total System Solutions (TSS)**
 - **Diversified portfolio of Smart, Connected and Secure Solutions**
 - **Software, firmware, reference designs to speed customer's time to market**
- **Provide solutions in Megatrend growth areas**
 - **Drives growth $\geq 2X$ corporate growth**

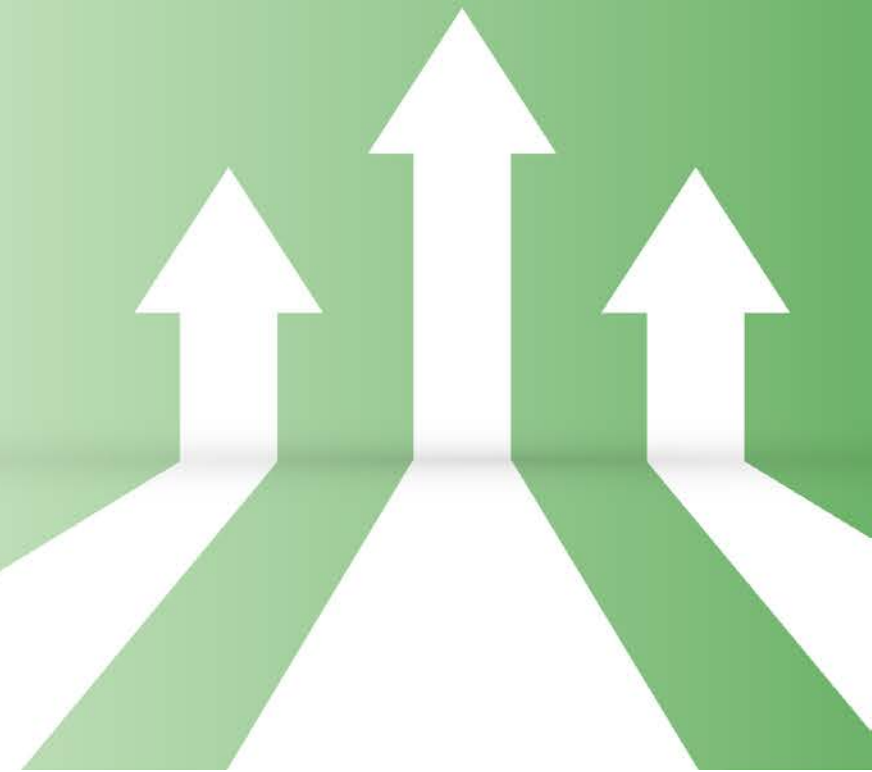

TSS- Total System Solutions

TSS = Total System Solutions Definition

TSS is a portfolio of hardware, software and services that when combined with business solutions brings value to our customers.

TSS Purpose

Create more customer recognized value with our business and technology solutions that maximizes Microchip's revenue growth.

Goal

Achieve greater than 2X industry growth with 6% to 8% CAGR.

Multiple TSS EV Charger Design Wins

EV Fast DC Charger

Total of 32 Microchip Parts

Why Microchip?

- SiC – Ruggedness, Performance, Reference Design
- Touch – Gesture Feature
- MCU – Modular Design with Software Support and Connectivity options for Scalability and Time to Market

Power

SiC

Gesture

MOSFET

MCU

Ethernet

ADC

Load
Switch

USB

Temp
Sensor

EEPROM

CAN

Microchip SAM \$1.4B in 2025

TSS eBike - Motor Control

Electric Vehicle Megatrend

Anchor Part Number

dsPIC33EP64MC504-I/ML

Total System Solutions

PIC18F26K83T-I/ML

ATA6561-GAQW-N *2

MCP6024T-I/ST

AT24C64D-XHM-T

MCP1754ST-5002E/MB *2

MCP1754ST-3002E/MB

MCP16301T-I/CHY *2

MCP16331T-E/CH

MIC28512-1YFL-TR



Repeated at 1000's of customers and applications!

Storage Attach Revenue

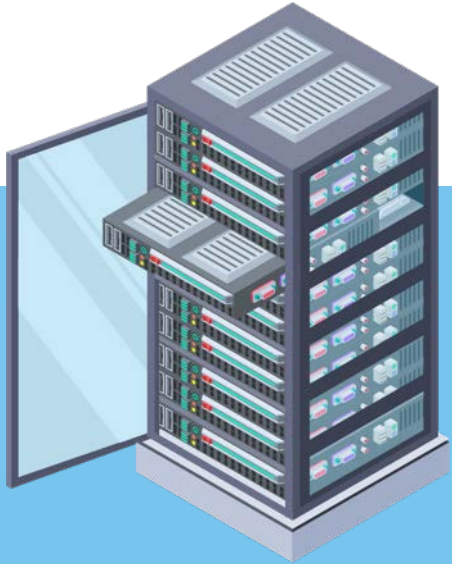

Data Center attach:
5-25
parts per board

Storage Anchor Products TSS SAM Summary

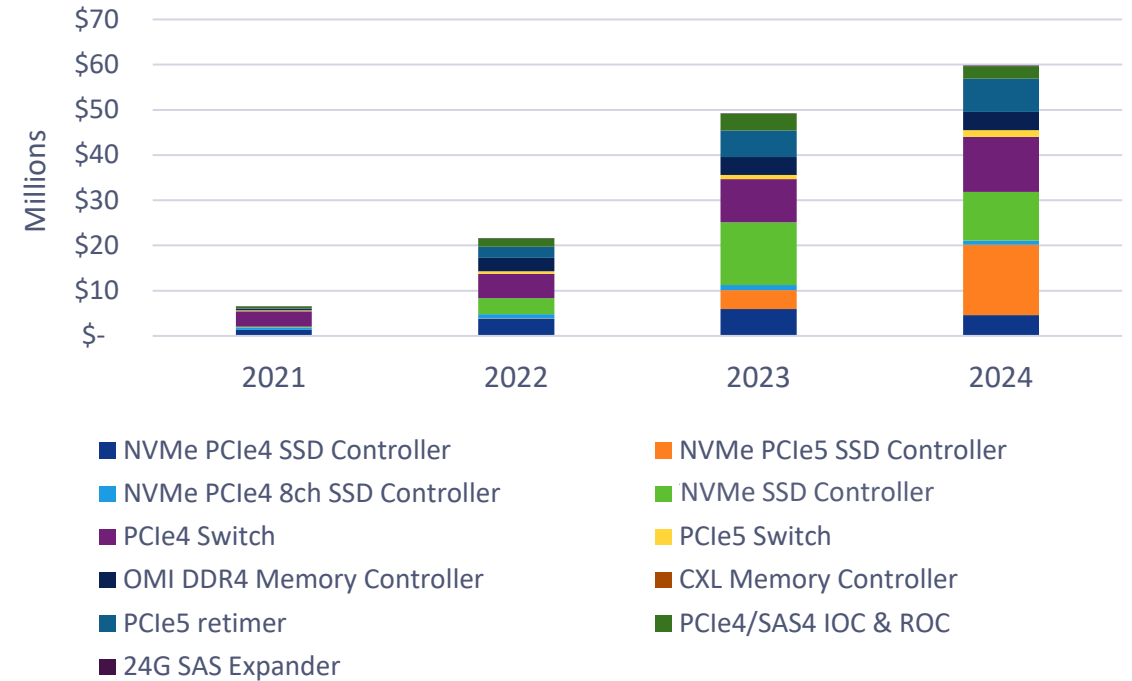

Estimate \$60M pull-through SAM for TSS components from DCS Anchor Products

Repeated 100s of times!

Turbocharging Revenue Growth Using AI/ML

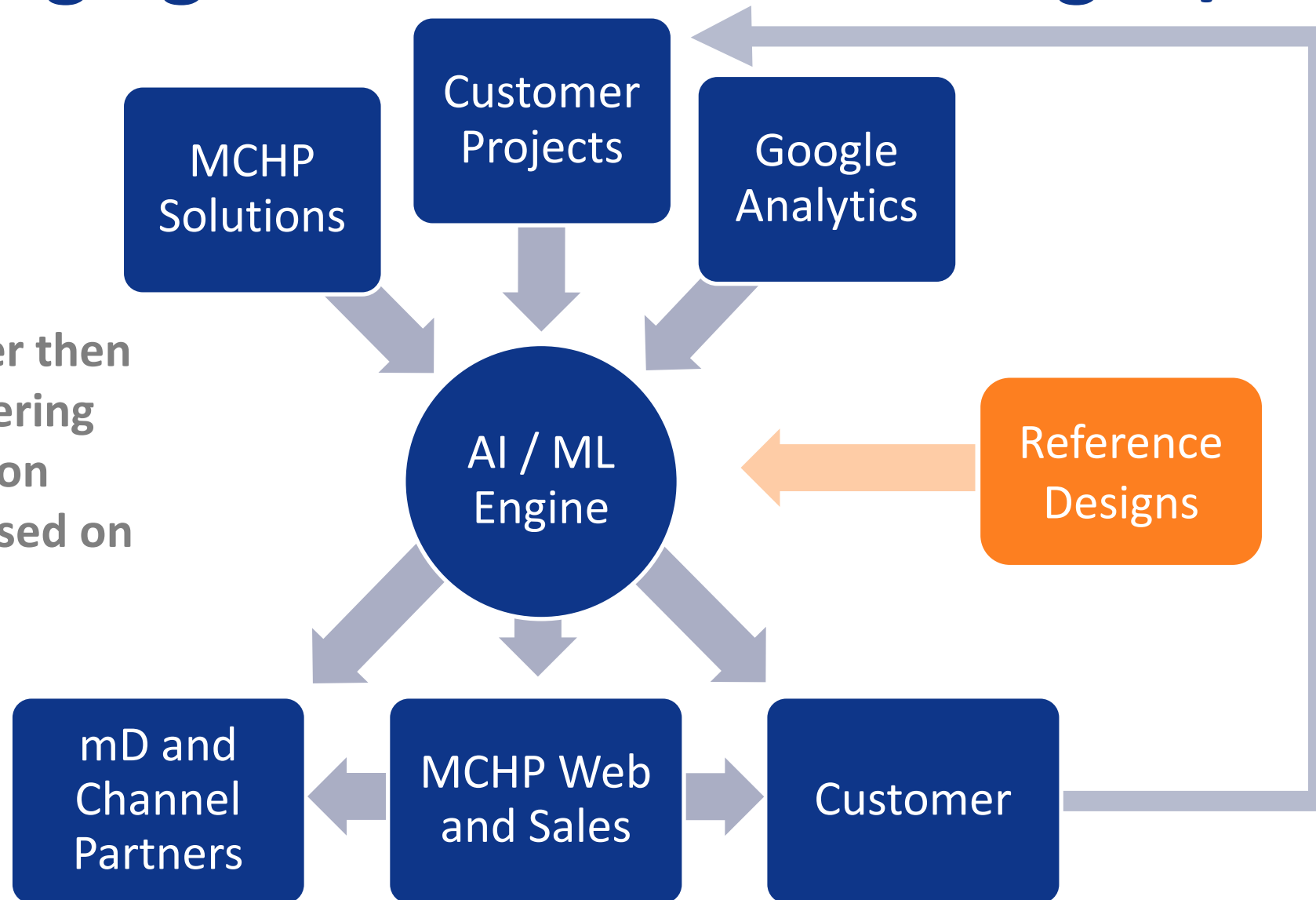

MCHP has greater than 250K devices offering millions of solution combinations based on customer needs

Megatrends Accelerating Growth

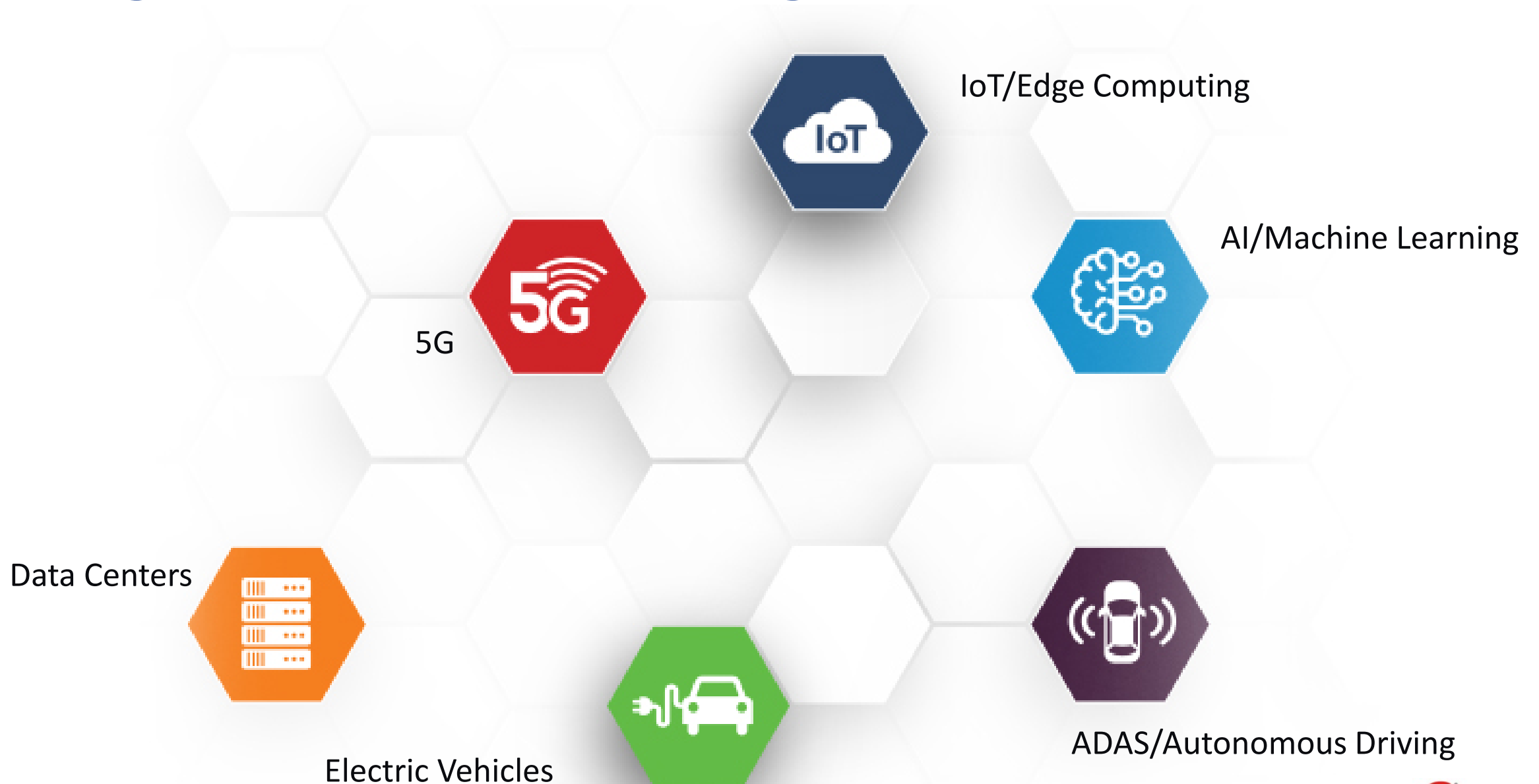

Summary

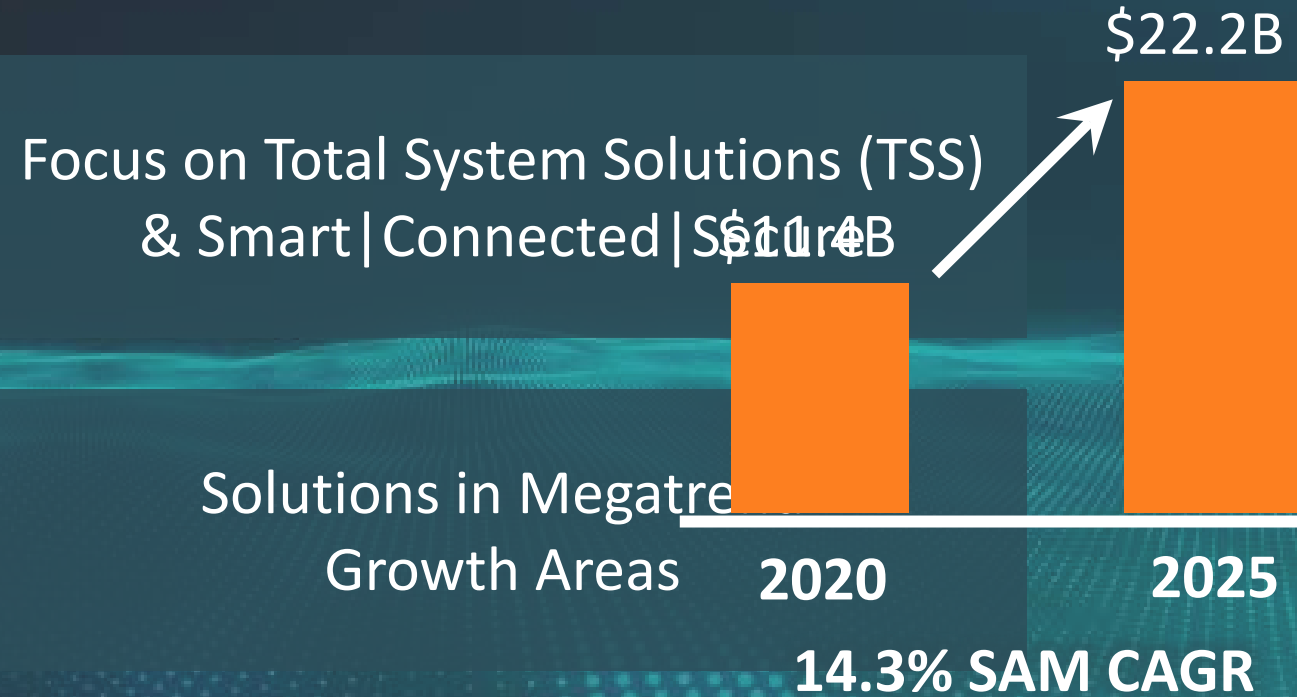

Growth Strategy

IoT/Edge Computing

Steve Drehobl, SVP MCU8 & MCU16

2021
Microchip's Investor and Analyst Day

IoT/Edge Computing – SAM Growth Rates



Challenges of Data Processing

Cloud vs. Edge



Methods needed to process large amounts of data and reduce latency

Push the data processing to the “Edge”

More devices, sending more data results in large cost and power increases at data centers

Engaging With IoT/Edge Computing Customers to Solve Complex Problems

Bring the SMART to IoT/Edge Computing
Connecting the SMART
System Solutions
simplifies the customer's challenge
SMART | CONNECTED | SECURE

Bringing SMART to IoT/Edge Computing

8-bit

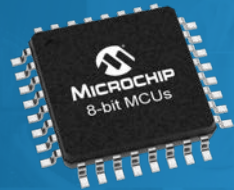

PIC® MCUs
AVR® MCUs

16-bit

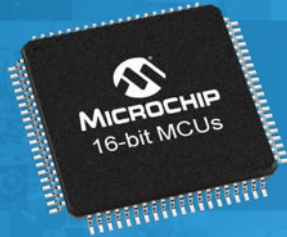

PIC® MCUs
dsPIC® DSCs

32-bit

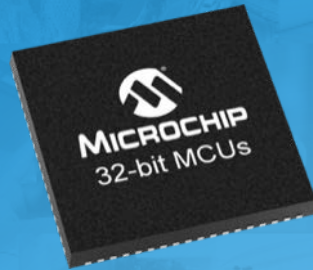

arm
MIPS



arm

SoC FPGAs



arm
w/ embedded
32-bit MCU



RISC-V®
w/ embedded
quad core
64-bit MPU

Bringing SMART With Machine Learning

Predictive Maintenance



8/16/32-bit MCUs

Smart Human Machine Interface



8/16/32-bit MCUs/MPUs

Smart Vision



32-bit MCUs/MPUs
FPGAs, SoC FPGAs

Bringing SMART With Machine Learning

Predictive Maintenance



Object Recognition & Classification



Entry-level machine learning
using 8-bit microcontrollers

Advanced AI/ML Using FPGAs
and SOC FPGAs

Connecting the SMART in IoT/Edge Computing

Leader in Wired USB and Ethernet Technology

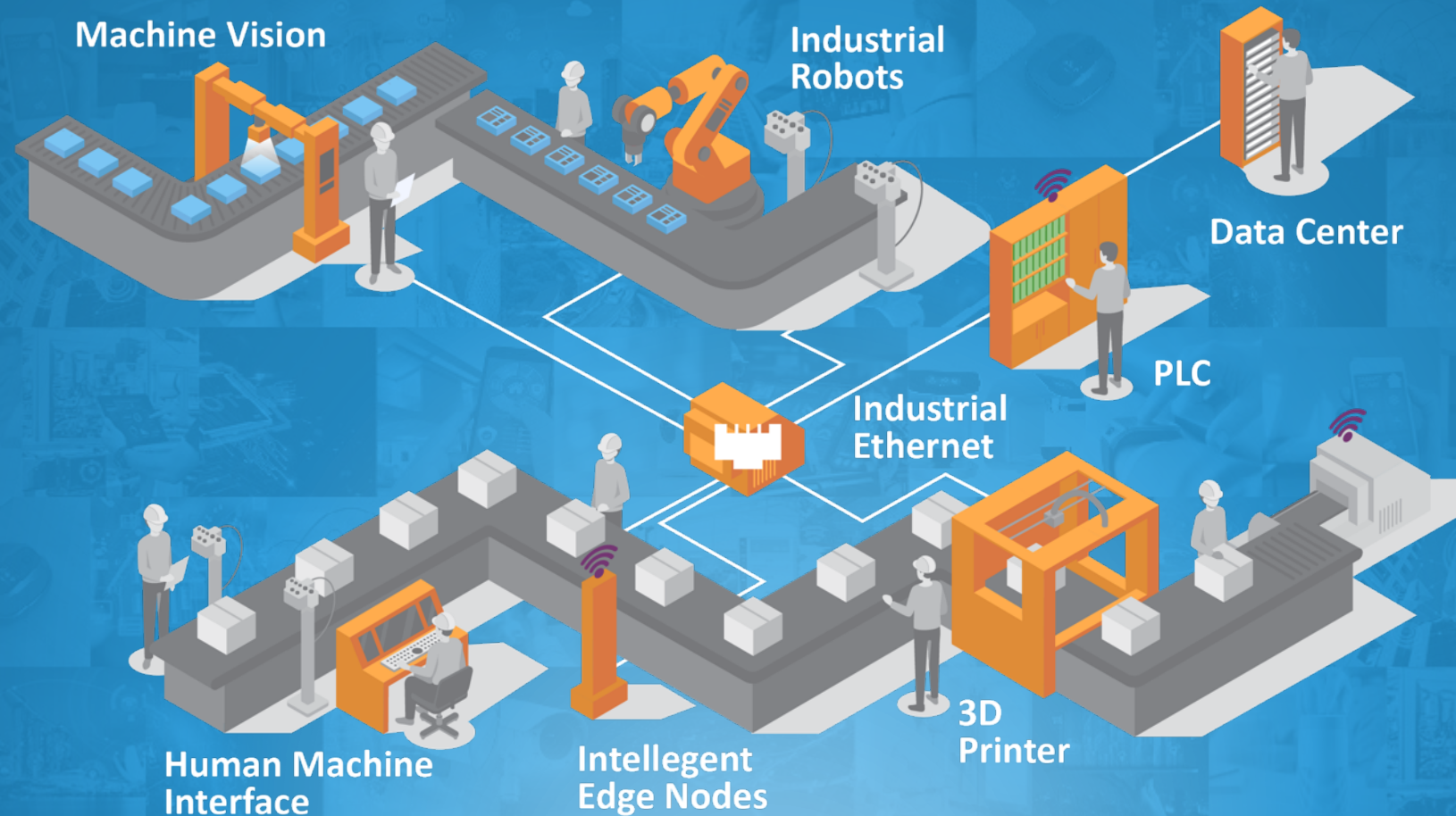

USB



Bluetooth®



WiFi®



zigbee



MICROCHIP
mPoE



Ethernet



MICROCHIP

Securing the SMART in IoT/Edge Computing

The Leader in Securing Embedded Data

Scalable Security Solutions

Security ICs
Security Design Partners



Security-Focused MCUs MPUs

Optimized Trust Platforms



Root of Trust | Secure Supply Chain | Anti-Tamper



Secure FPGAs









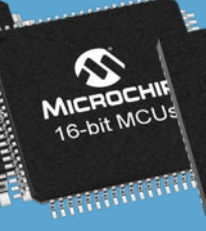

From Root-of-Trust to DoD-level Security

Total System Solutions for IoT/Edge Computing

Timing & Frequency  Power Management

Analog  Mixed Signal



TSS With Breadth of Microchip Portfolio

Simplify the Customer's Complexity – Accelerate Microchip Growth

Well Positioned For IoT/Edge Growth at 2X of Microchip's Organic Growth

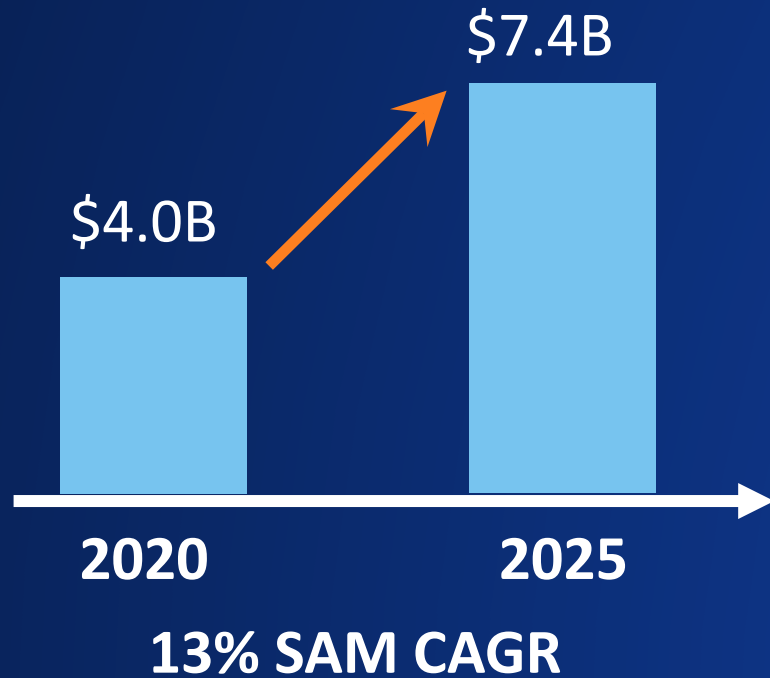

Bringing SMART to IoT/Edge Computing
Connecting the SMART
Securing it ALL
Total IoT/Edge System Solutions

Growth Strategy

Data Center

2021
Microchip's Investor and Analyst Day

Pete Hazen, VP Data Center Solutions

Data Center Summary

Delivering Smart,
Connected and Secure
Solutions

SAM growing to ~\$4B
with revenue growth
2X the market

Partner of choice to
enable Total System
Solutions for
Cloud Providers, Server
and Storage OEMs &
Media Vendors

Microchip Data Center Solutions

Connecting, Managing & Securing the World's Information



**Storage
Infrastructure**

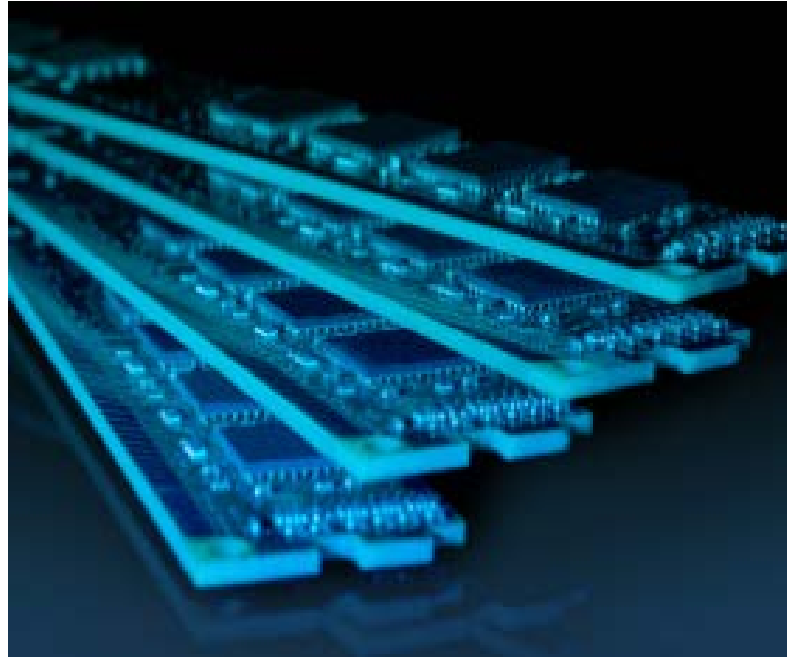

**Memory
Infrastructure**

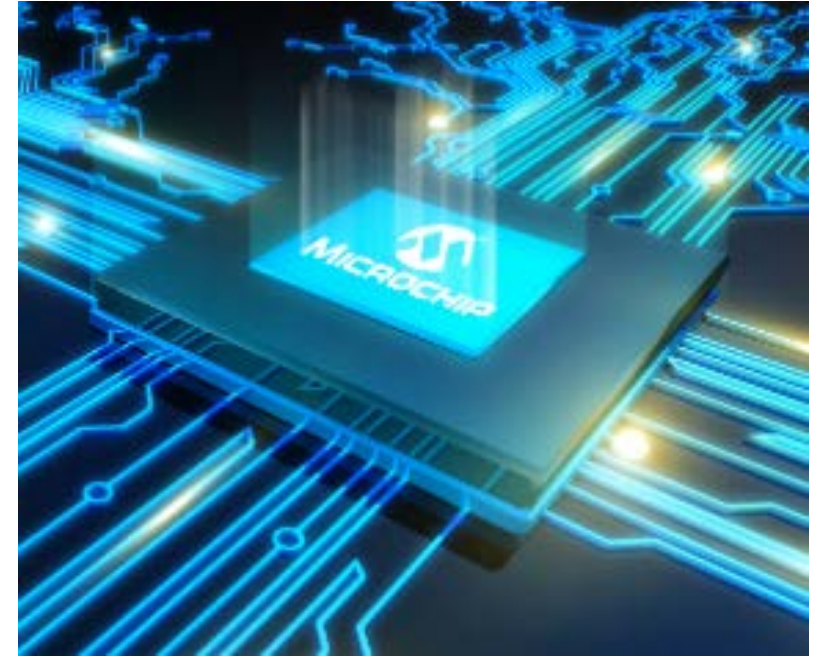

**Compute
Infrastructure**

Data Center Market Growth

Strong Market Growth

- SAM growing by +\$1B
- >7.5% CAGR

Proven Track Record

- Growing >2X the market
- 3rd consecutive year of double-digit growth

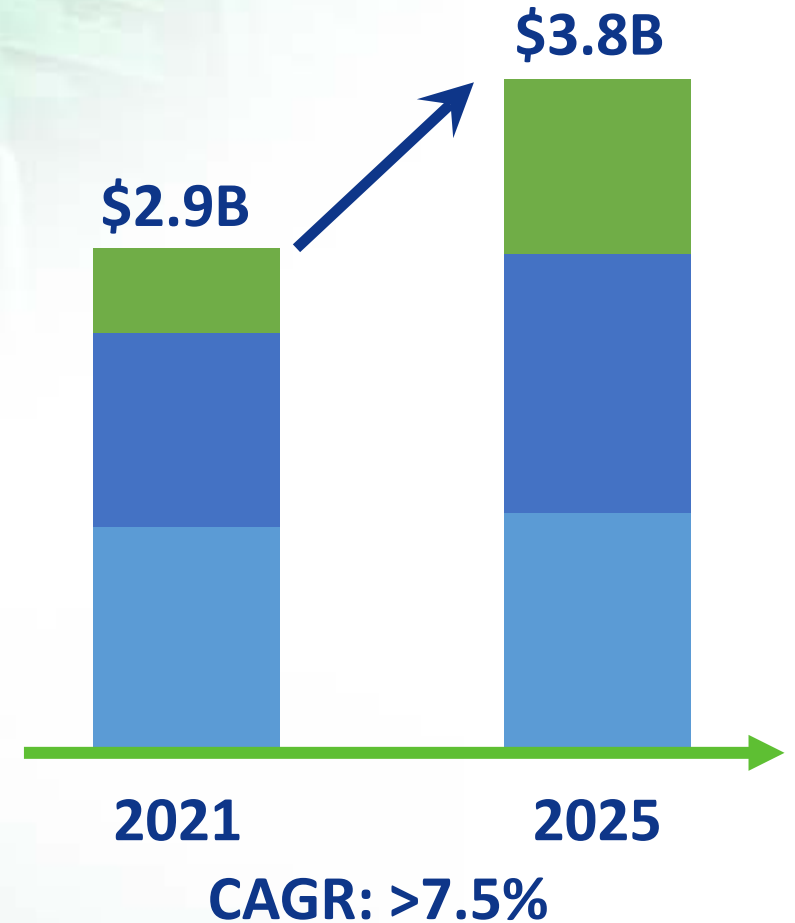
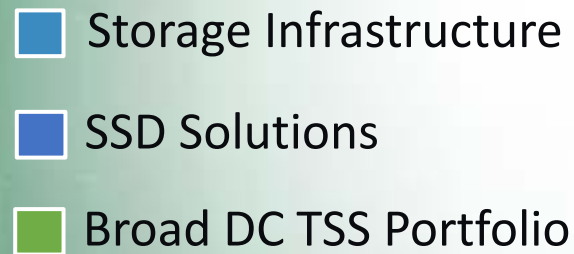

Data Center Market Segments

Cloud Providers & Server OEMs

Storage System OEMs

Storage & Compute Infrastructure

Smart Storage Controllers

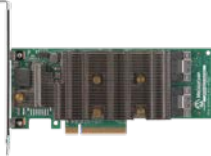

Expanders

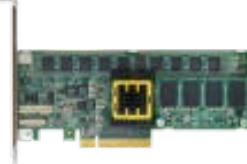

Switches and Fabrics



Storage Controllers

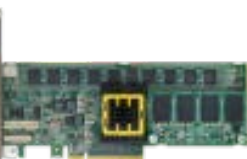

Cloud Providers, SSDs, Storage & Server OEMs

Solid-State Drive Solutions

Flashtec® SSD Controllers



Performance Controllers



Mainstream Controllers

Cloud Providers, Server/Storage OEMs, Media OEMs

Broad Data Center TSS Portfolio

Memory Infrastructure

Inter- Data Center Communications

Microcontrollers

Power Conversion

Timing and Synchronization

System Management

Secure Solutions

Leading Provider of Data Center Solutions

- **Deep Customer Engagements with Cloud Providers, ODMs, OEMs & Media Vendors**
- **Configurable Architectures enable Customer Personalization & Differentiation**
- **Broad Ecosystem Support enabling Compute and AI/ML Servers, Storage Servers and SSDs**
- **Products Aligned to Market Transitions & Customer Needs**

Smart Storage Controllers & Expanders

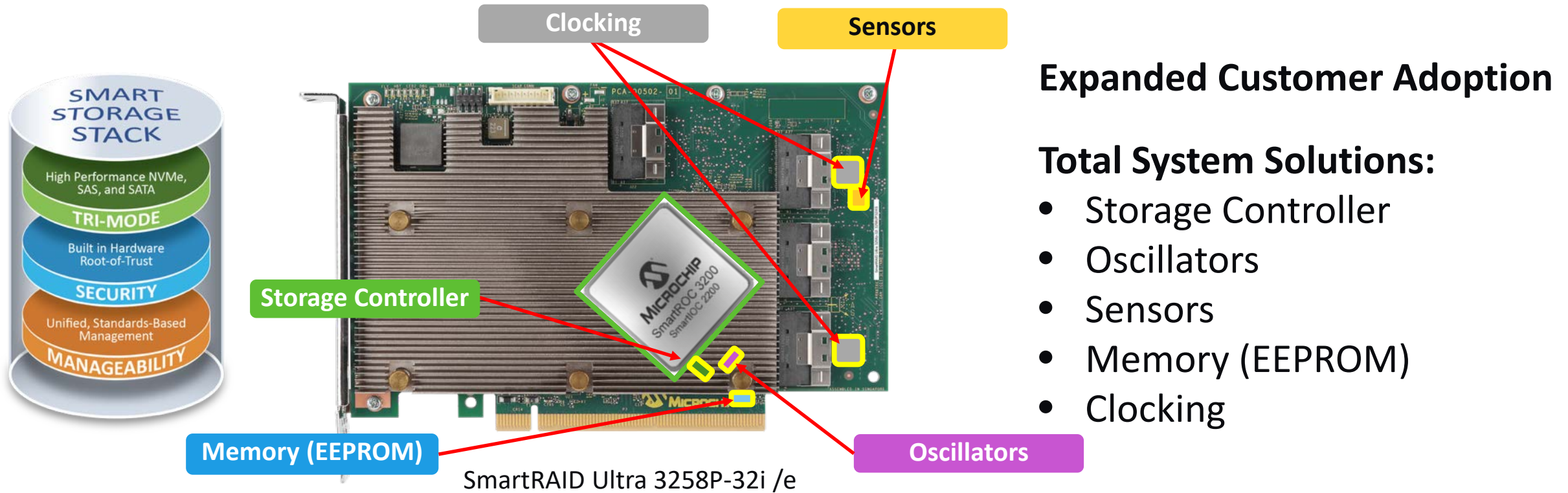

- **Trusted Enterprise Solution with Tens of Millions of Storage Controllers shipped to leading Cloud Providers and Server OEMs**
- **Industry-leading Performance, Low Power and Interoperability**
- **Enterprise Class Data Protection & Security**

Flashtec® NVMe SSD Solutions

Strong Market Growth

Total Systems Solutions

- SSD Controller
- Sensors
- Microcontroller
- Memory (EEPROM)
- Clocking

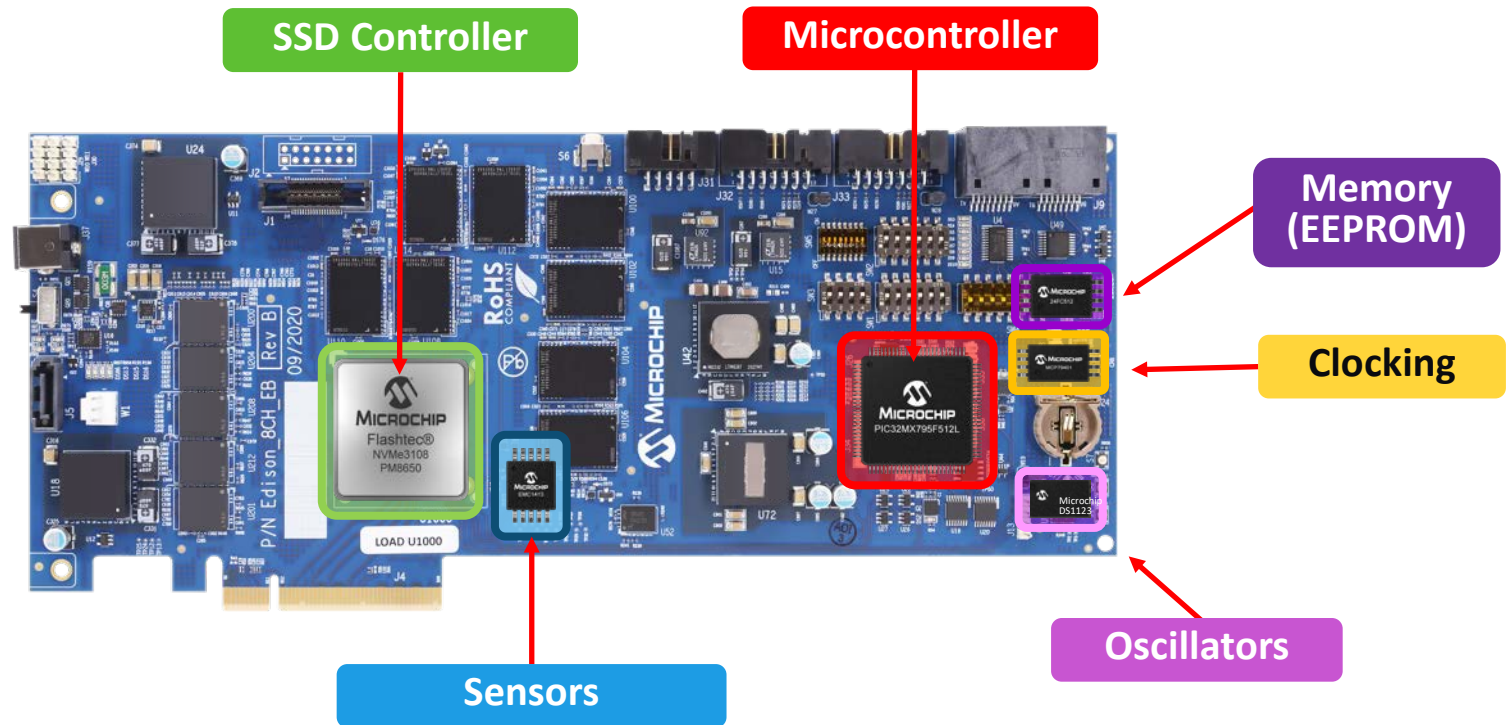

- 4 Generations of SSD Controllers for the Datacenter
- Broad Design-Win Footprint with Cloud Providers, SSD and Storage/Server OEMs
- Highly Flexible and Programmable Architecture
- Standards-based Solutions with broad Ecosystem Support

Securing Information from Edge to Cloud

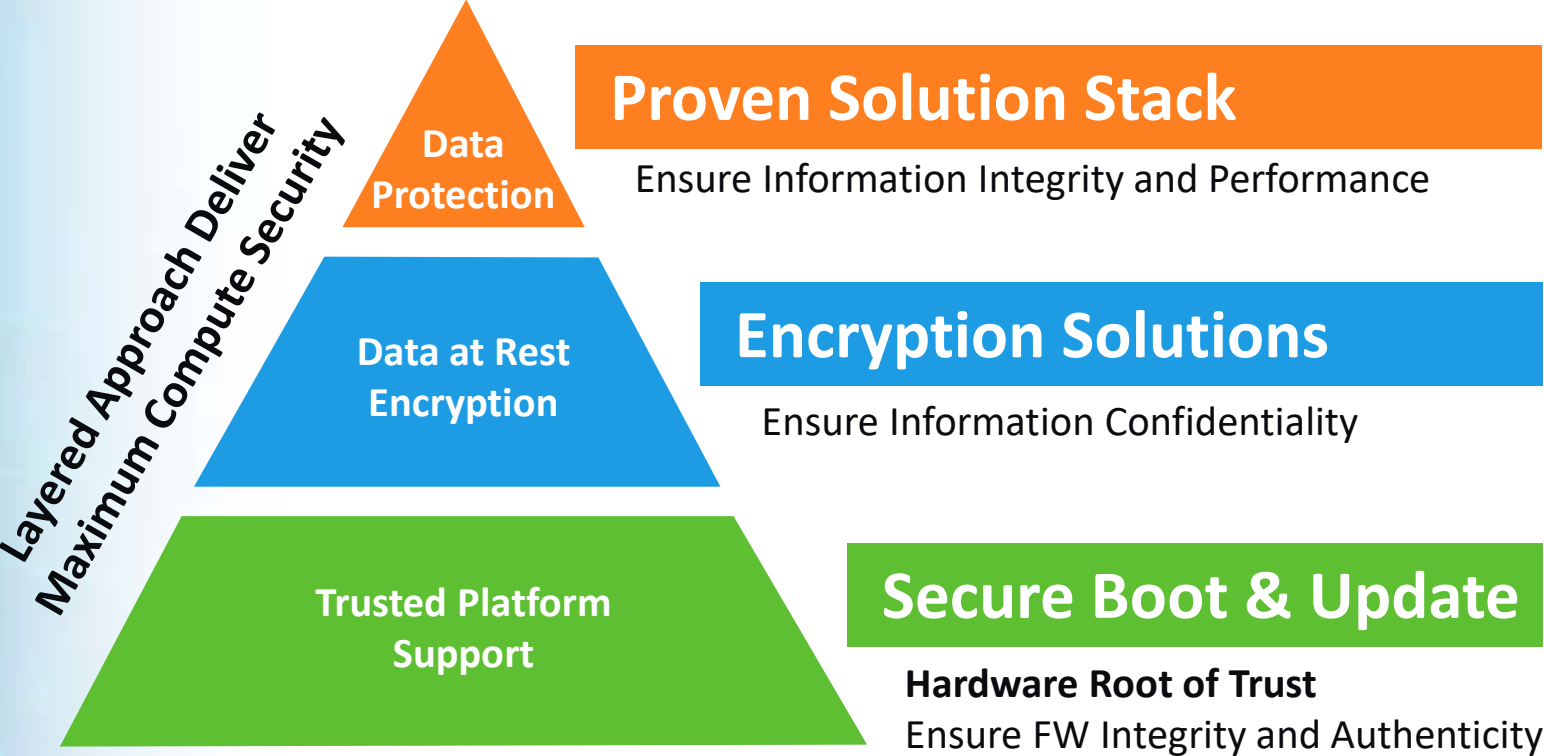
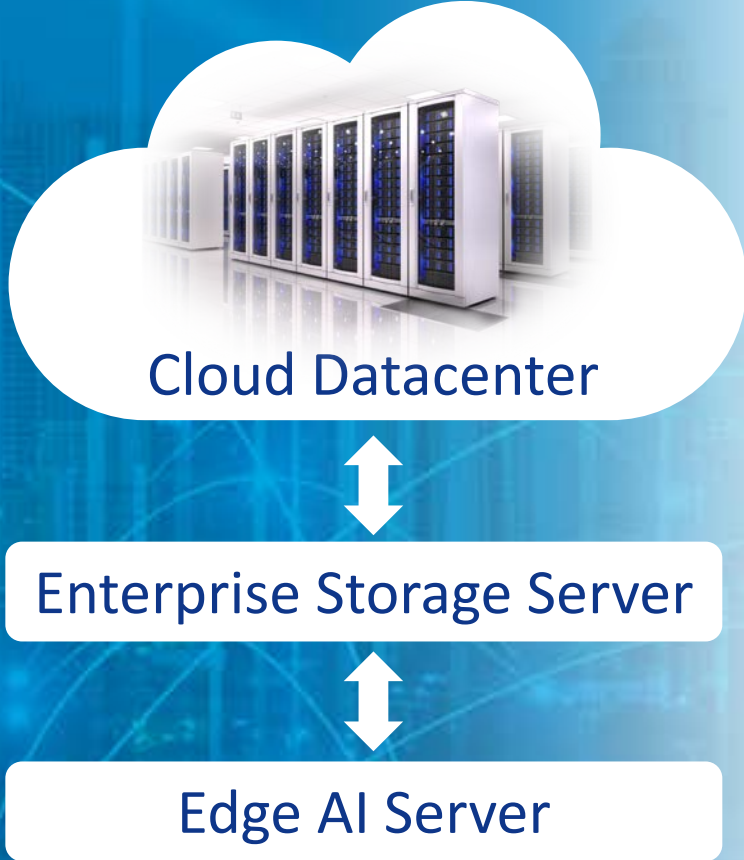

Data Center Summary

Delivering Smart,
Connected and Secure
Solutions

SAM growing to ~\$4B
with revenue growth
2X the market

Partner of choice to
enable Total System
Solutions for
Cloud Providers, Server
and Storage OEMs &
Media Vendors

Growth Strategy

ADAS & EV

2021
Microchip's Investor and Analyst Day

Matthias Kaestner, VP Automotive

Automotive Semi TAM and Megatrend SAM

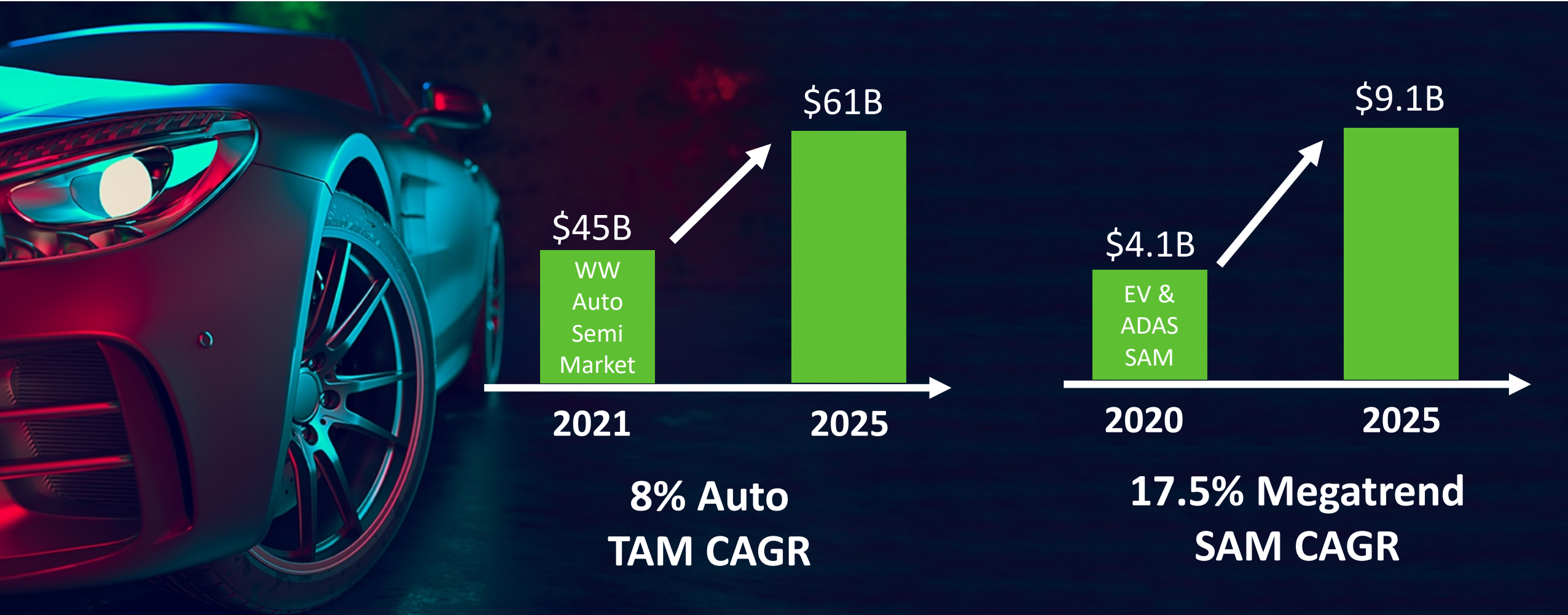

Automotive Megatrends



15%
Semiconductor
CAGR '21-'25

**Safe and
Convenient:**
Sensor Network on Wheels



**Autonomous
and Secure:**
Datacenter on Wheels

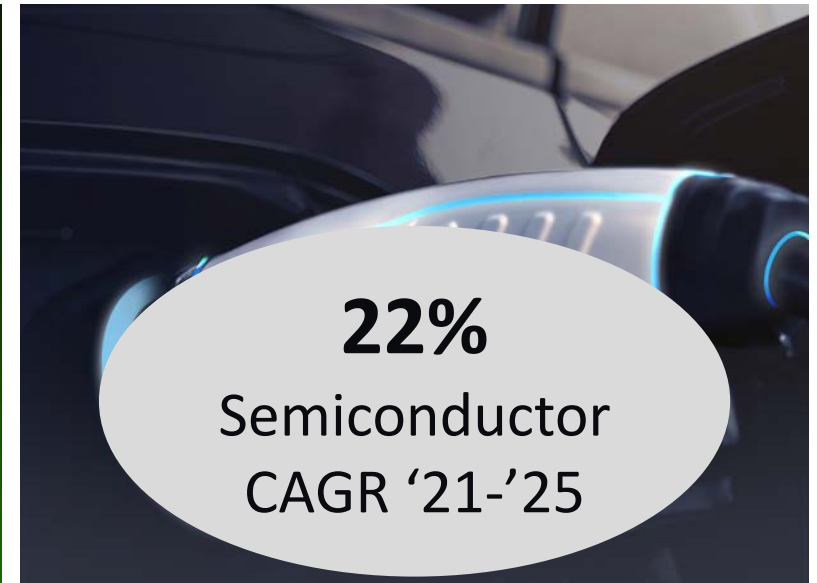

22%
Semiconductor
CAGR '21-'25

Electrified:
Energy Storage and Energy
Conversion on Wheels

From Buttons and Switches (2013)...



...to Personalized Screens and Touch Sensors



#1 in Touch Screens

#1 in Touch Buttons

10+ touch devices/car

Assisted Driving: Safety and Comfort

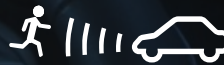
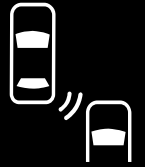

LED Matrix



Sensor Processing

- MCUs, MPUs & FPGAs
- Security/Trust Anchor
- Oscillators
- Memory
- Power Management
- Amplifiers
- ADC & DAC
- Thermal Management

Communication

- LIN
- CAN & CANFD Controllers
- 802.3 Ethernet controllers
- 10Base-T1S
- 100Base-T1
- 1000Base-T1
- CoaXPress®

Vehicle Computer/ ADAS Controller

- PCIe® Switch
- FPGA & MPUs
- Power Management
- Ethernet
- Security/Trust Anchor
- MEMS Clock
- Clock Retimers
- Memory

Automotive Value Paradigm Shift

Past - Hardware Defined
Handling, power, torque,
speed



Automotive Value Paradigm Shift

**Future - Software Defined
ADAS, Infotainment, OTA updates,
personalization, feature upgrades,
services on demand**



... Datacenter on Wheels: PCIe[®] and Ethernet

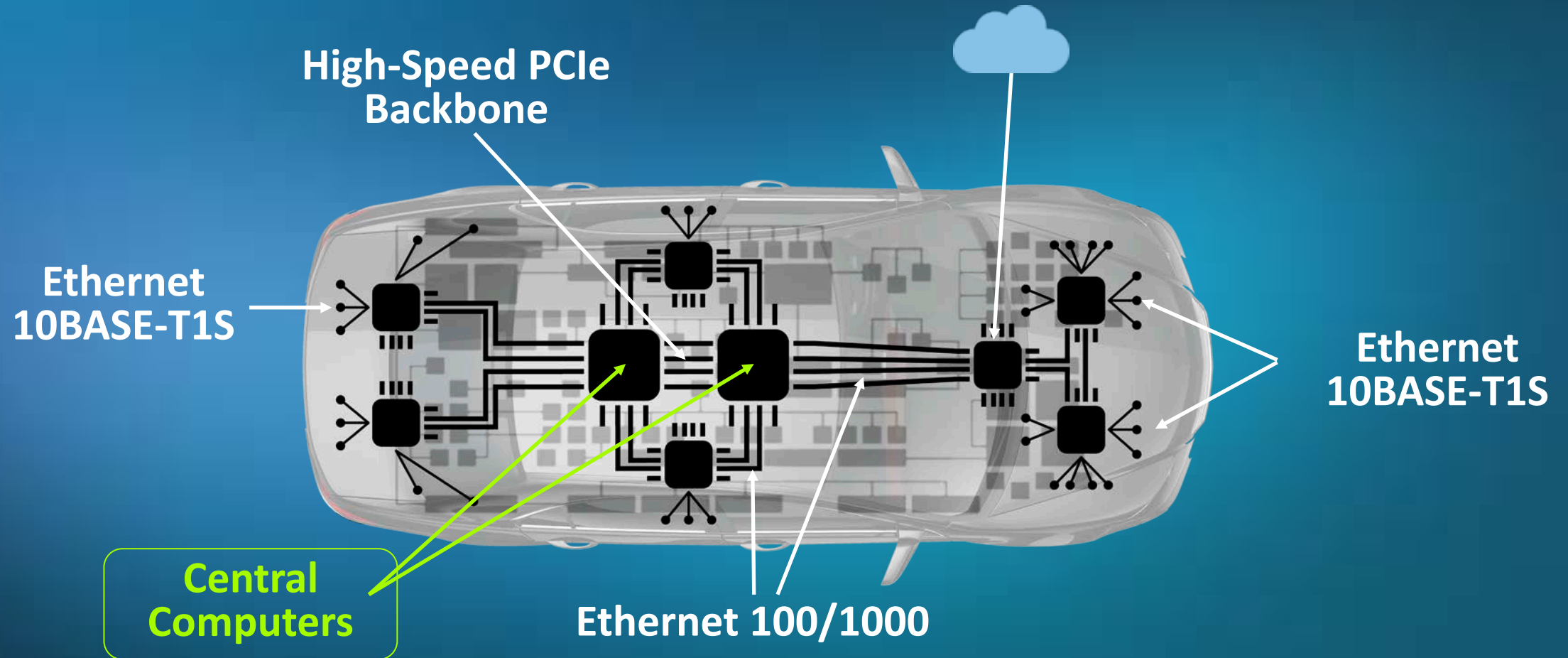

Energy Conversion and Storage on Wheels

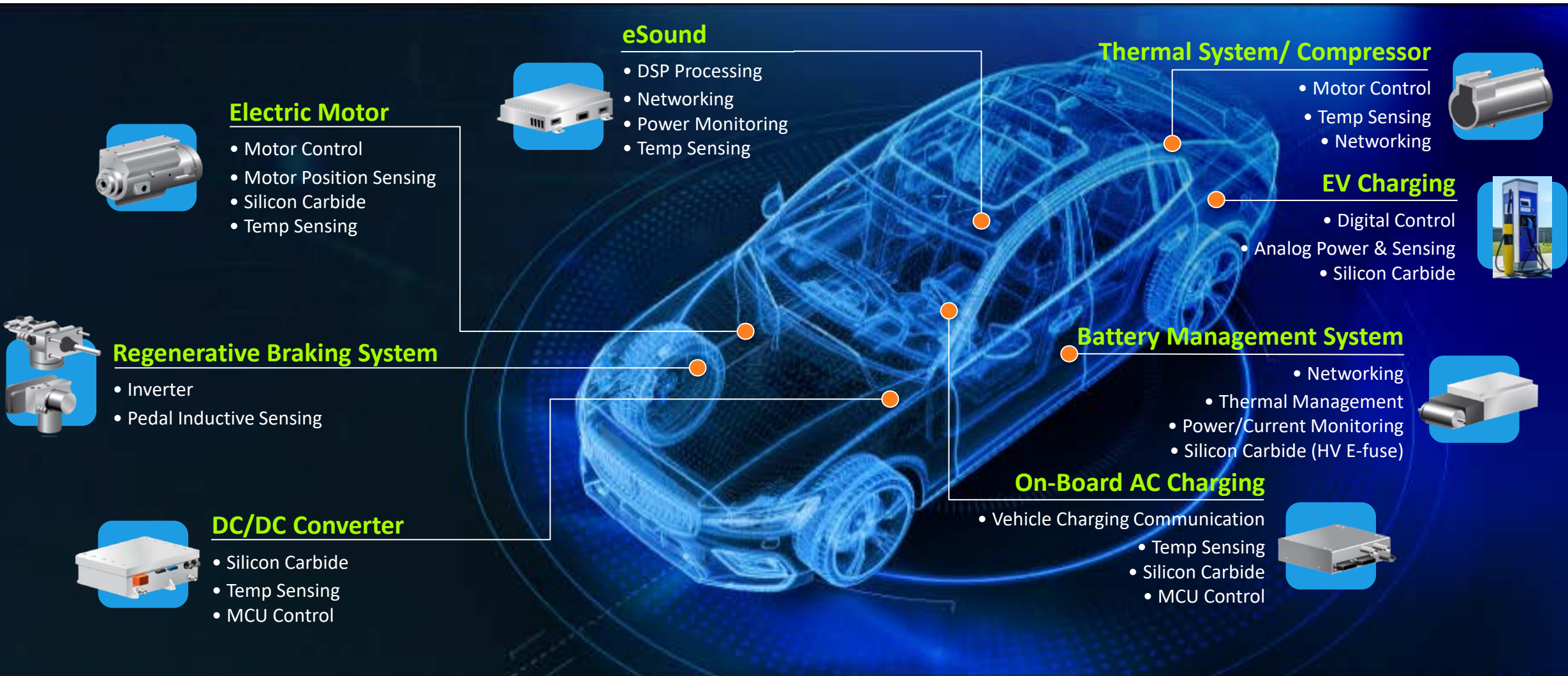

EV Fast Charger

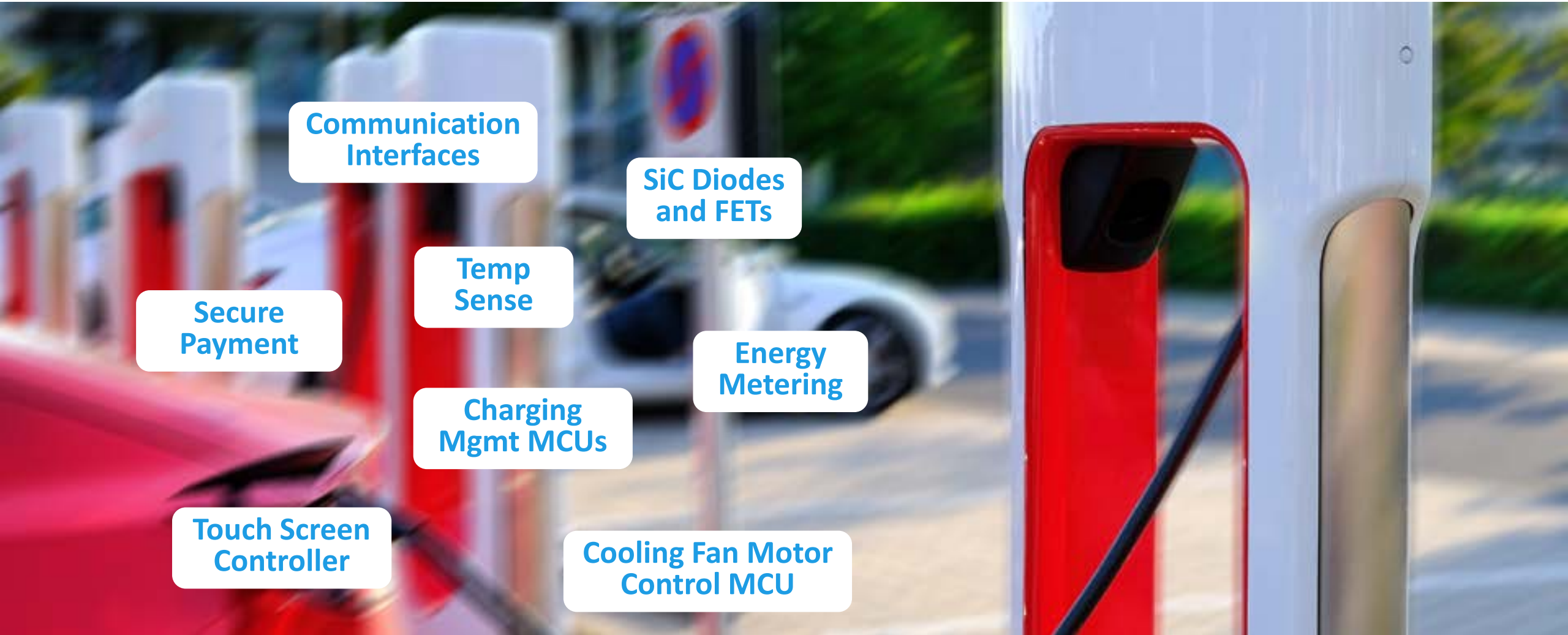

SiC Beyond e-Mobility...

Highly Efficient Power Conversion



Automotive Megatrends



**Safe and
Convenient:**

Sensor Network on Wheels

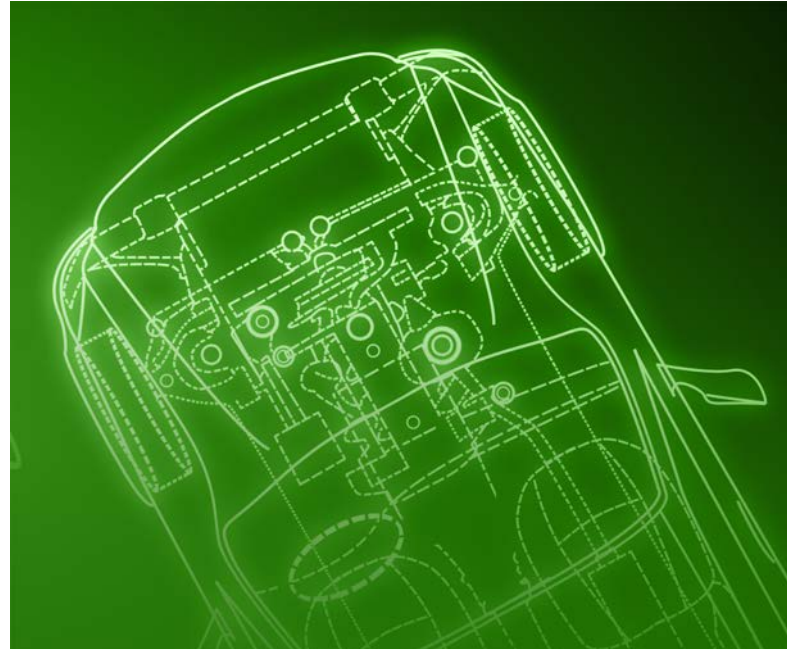

**Autonomous
and Secure:**

Datacenter on Wheels



Electrified:

**Energy Storage and Energy
Conversion on Wheels**

Growth Strategy

5G

2021
Microchip's Investor and Analyst Day

Patrick Johnson, SVP Mixed Signal, Timing & FPGA

4G to 5G – What is the Difference?

10x Bandwidth
10x IoT Connections
10X Decrease in Latency

5G
FIFTH GENERATION

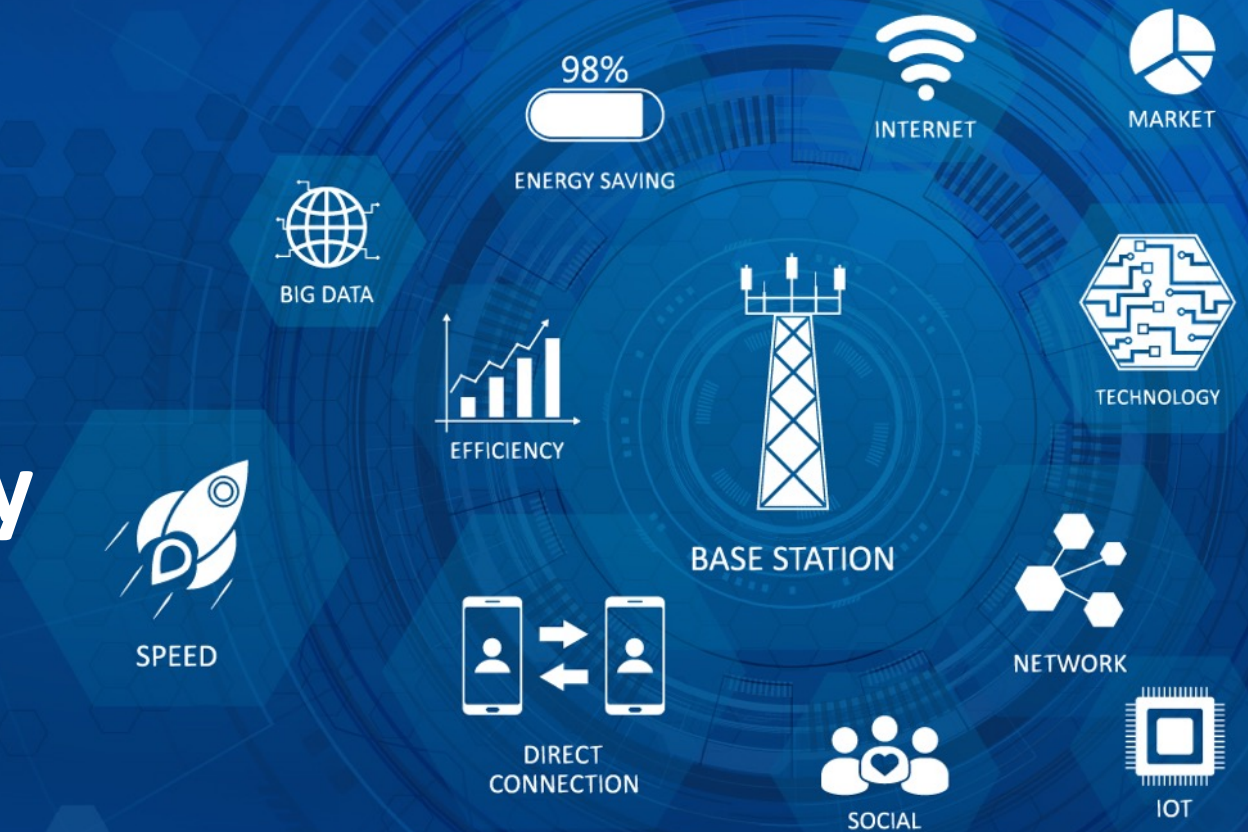

4G/5G Latency

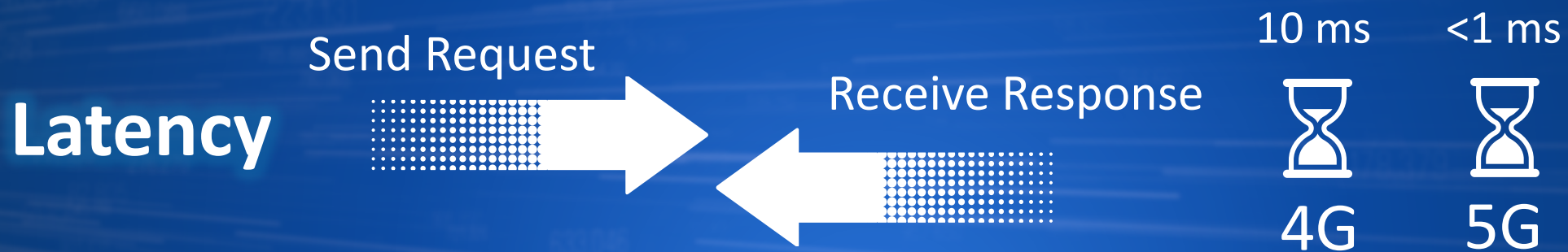
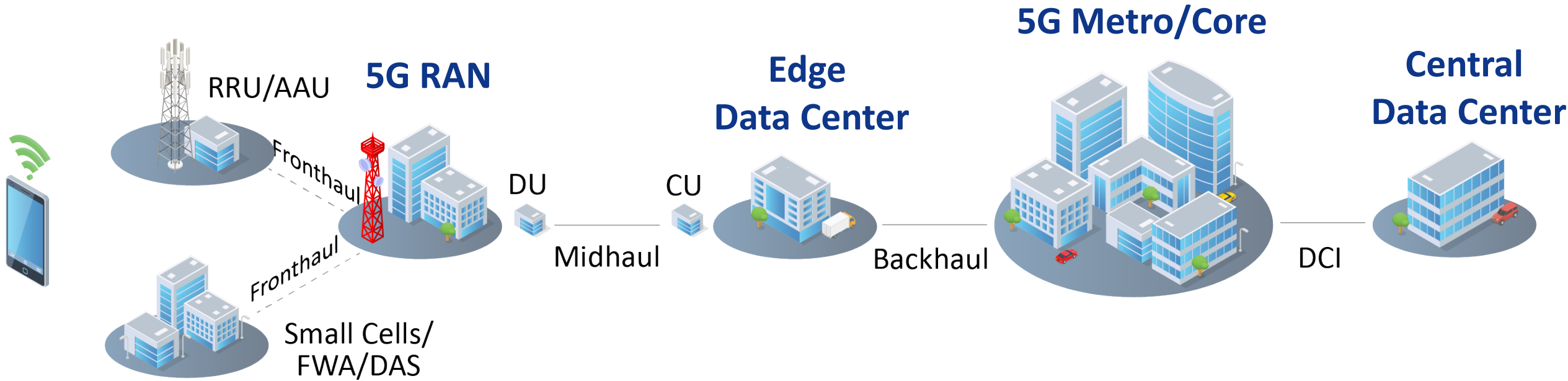

5G Timing/Network Synchronization

Integrated Grand Master 1100 

5G RAN

TimeProvider® 4100 

Edge

Data Center

TimeProvider 4100 

5G Metro/Core

TimeProvider 4100 

Central Data Center

SyncServer® S650 Time Server 

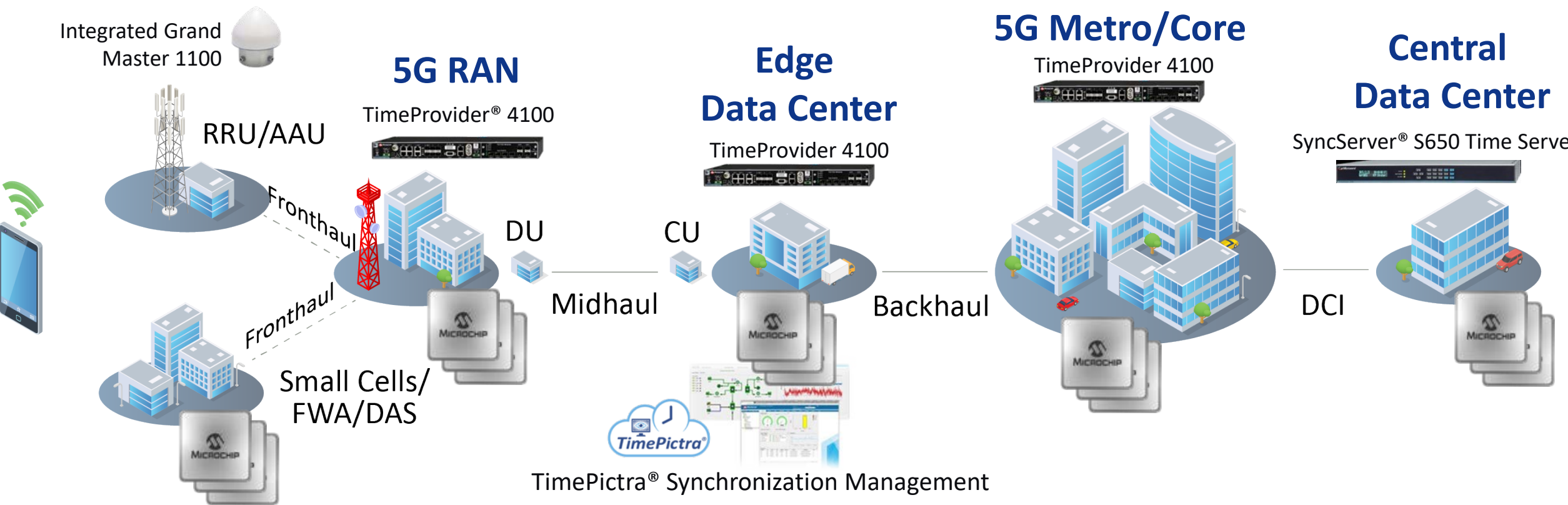

Industry leader in SyncE/1588 network synchronization



>90% Commercial Clocks contributing to Universal Coordinated Time (UTC) is powered by Microchip

5G

7 out of Top 10 Mobile Operators use Microchip Timing Solutions

5G Semiconductor Market

SAM Growth Rates

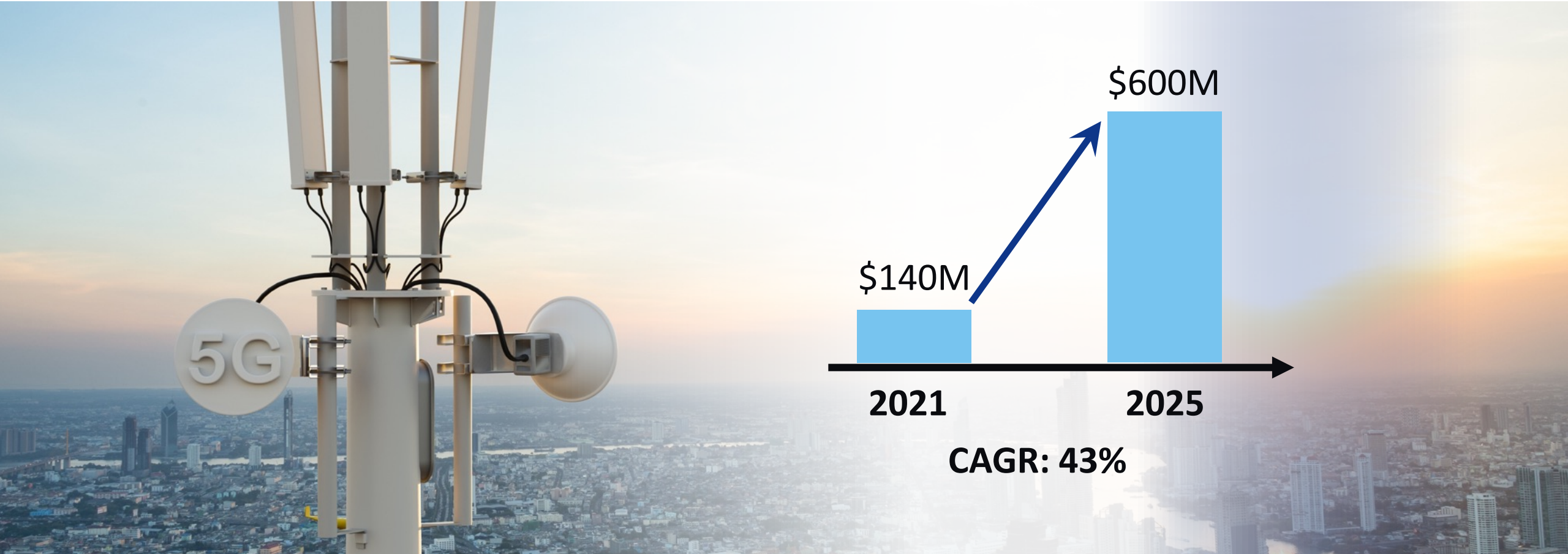

End-to-End Total System Solutions

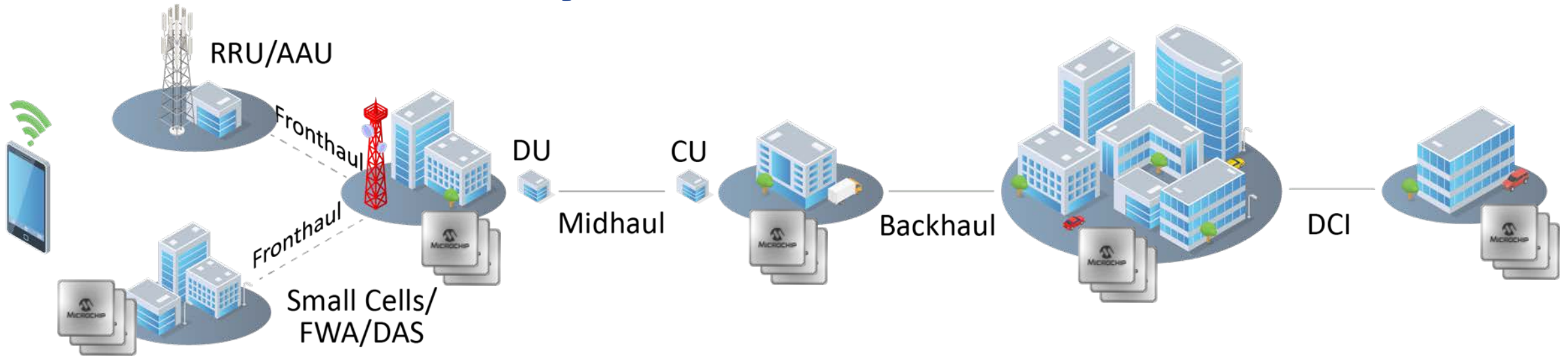

Timing Solutions

- **Timing System:** Grandmasters, pRTC
- **Timing Software:** IEEE 1588 Algorithm
- **Timing Chipset:** High-Accuracy PLL, Buffers
- **Precision Oscillators:** OCXO, TCXO, Cesium, Rb

Power Solutions

- **Digital Power ICs:** PMIC, Secure MCU
- **Analog Power ICs:** SiC, PMIC
- **PoE:** PoE IC, Midspans, Switch

Security Solutions

- **IC:** Root of Trust, TPM, Authentication
- **FPGA:** Secure Boot, DPA resistant

RF Solutions

- **PA:** GaN for mmwave
- **FWA:** Varactor Diodes

Network Connectivity

- **Ethernet PHY:** 1GE to 800GE MACsec, Class C/D,
- **Ethernet Switch:** Nx10G/25G, TSN Switch, Security
- **OTN Processors:** CPRI/Ethernet, 100/400G Optical

FPGA

- **Peripheral/IO FPGA:** Instant On, High Integration
- **Protocol Converter:** Ethernet, CPRI, PCIe®
- Low Power; Small Form Factor

100G+ Optical Transport Network (OTN)

DIGI OTN Processors Reference Design

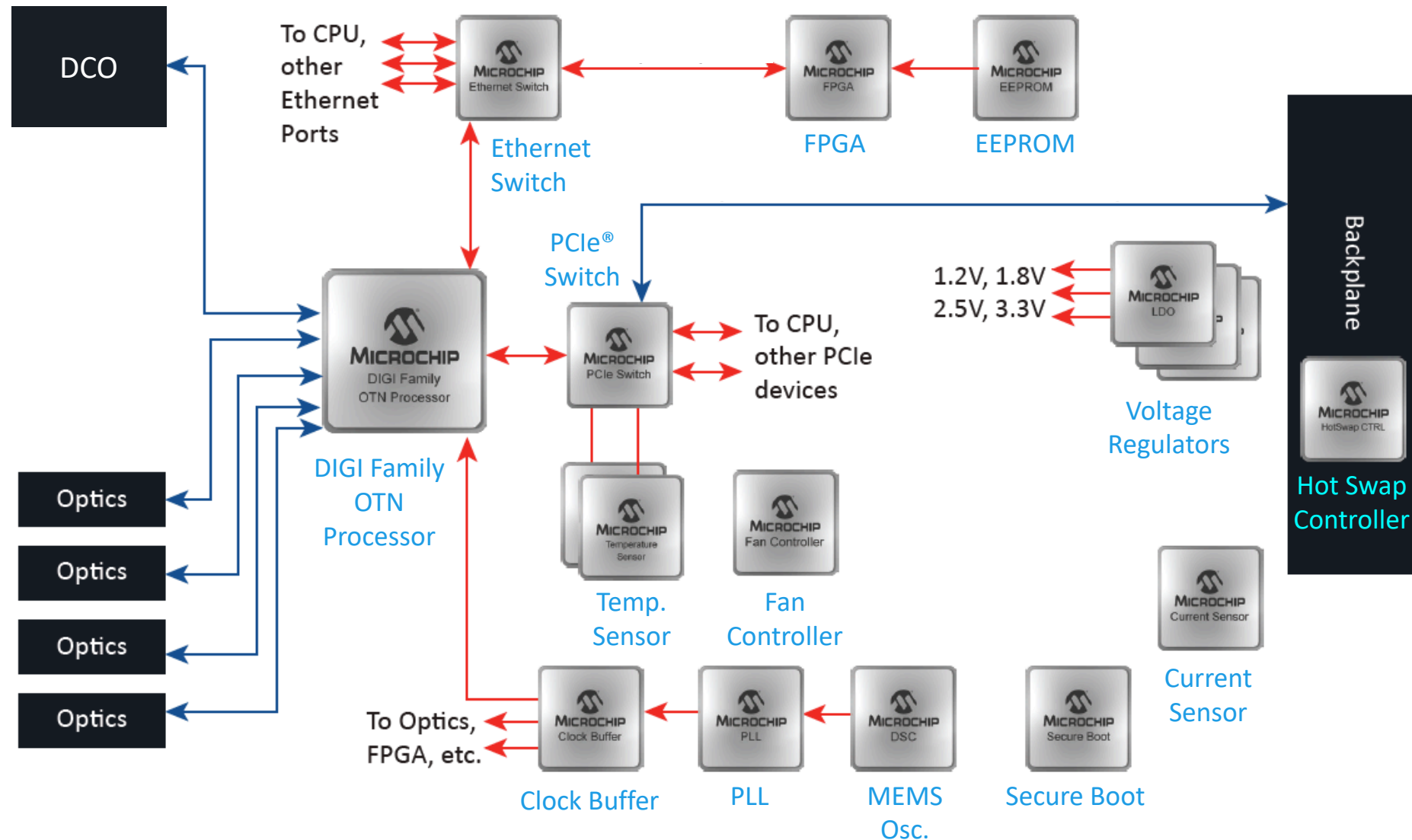

Smart SFP

Small Form-Factor Pluggable

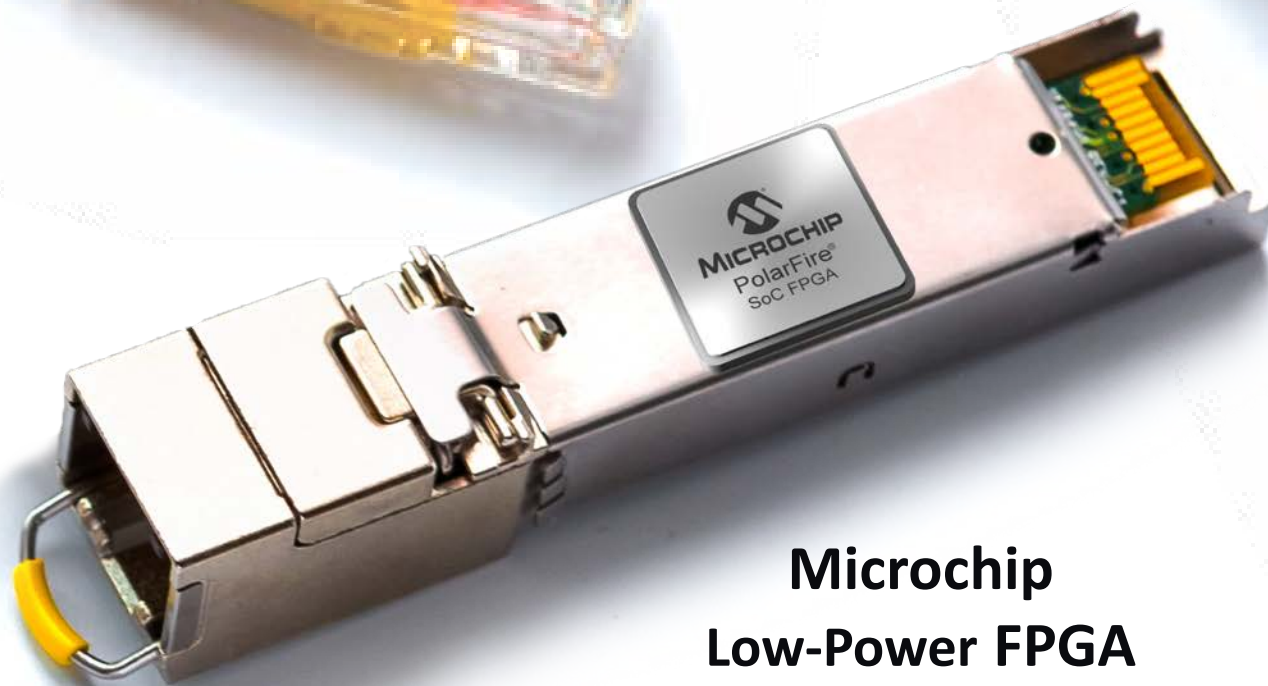

**Microchip
Low-Power FPGA**

Industry's Broadest Timing Solutions

Timing Silicon

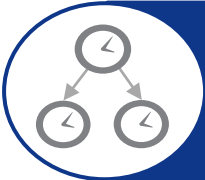
- 

Network Synchronization
- 

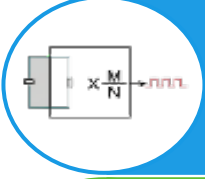
Oscillators
- 

Clock Generation
- 

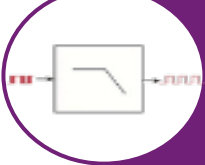
Fan Out Buffers
- 

Jitter Attenuators

Timing Software

- IEEE-1588 & SyncE Algorithm Software
- PTP & Servo Algorithm Software
- Synchronization & Management Software
- Network Analytics Software
- Network Management & Monitoring Software

Timing Systems

- Grandmaster
TimeProvider® Series

- Time Server
SyncServer® Instrument

- Clock Products
CSAC, Rubidium, Cesium

- Network Management
TimePictra® Platform

- GNSS Firewall
Bluesky™ Technology



Only Supplier with Complete Timing Offering Silicon, Software and Systems

Summary



5G is 10x Over 4G

Driving 43% CAGR SAM growth
opportunity for Microchip

Microchip Timing & Synchronization
provides the *heartbeat* for 5G Networks

Growth Strategy

Client Engagement

2021
Microchip's Investor and Analyst Day

Joe Krawczyk, VP Worldwide Client Engagement

Customer Engagement Strategy

Growing a broad and diverse customer base

Building on a foundation of diverse and sustainable revenue



Growing a Broad and Diverse Customer Base

Serving customers
at every level,
growing design
wins to revenue



Microchip Team Serving Highest-Value Customers

- Aligned with Microchip business units, deployed to highest value customers and megatrend growth
- Microchip sales resource coverage on ~7,000 Focus Accounts
- Supported by network of field application engineers, engineering specialist, and customer service professionals
- Highly collaborative non-commissioned culture
- Nearly every global household name is our customer



Multiplying Results Through Our Partners

Different Partners Bring Unique Value to Customers

Global Distributors

- Global footprint and resources
- Wide line card
- Strengths: logistics, deep inventory, finance and global business

Regional Distributors

- Regional footprint and resources
- Narrow line card
- Strengths: demand creation, TSS, Specialization and Regional business

Catalog Distributors

- Global e-commerce footprint
- Strengths: e-commerce, widest inventory mix, Engineering design focus

Independent Sales Reps

- Regional footprint and resources
- Narrow line card
- Strengths: demand creation and regional business

Delivering Web-Based Self-Sufficiency to Broad Market

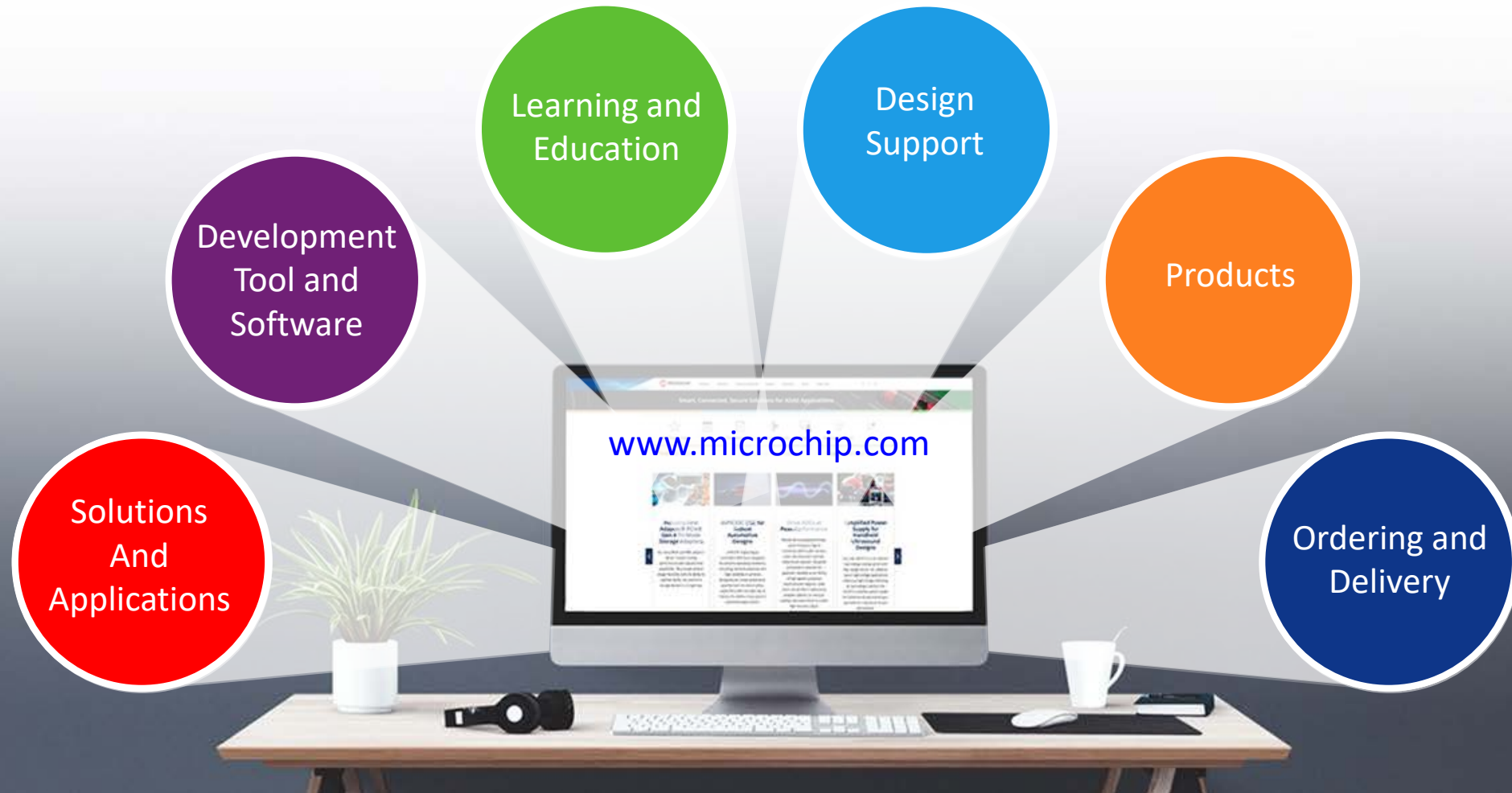

Ecosystem enabling customer discovery, design and delivery

Foundation of Diverse Revenue

Revenue Fulfillment

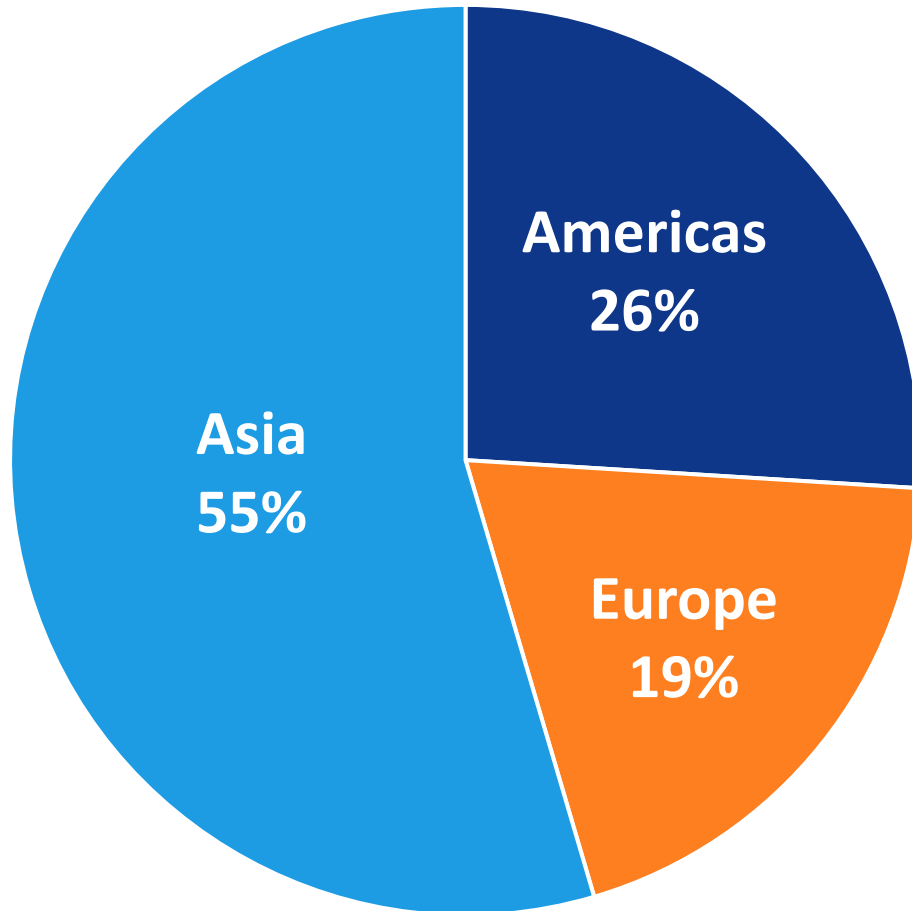

Revenue Creation

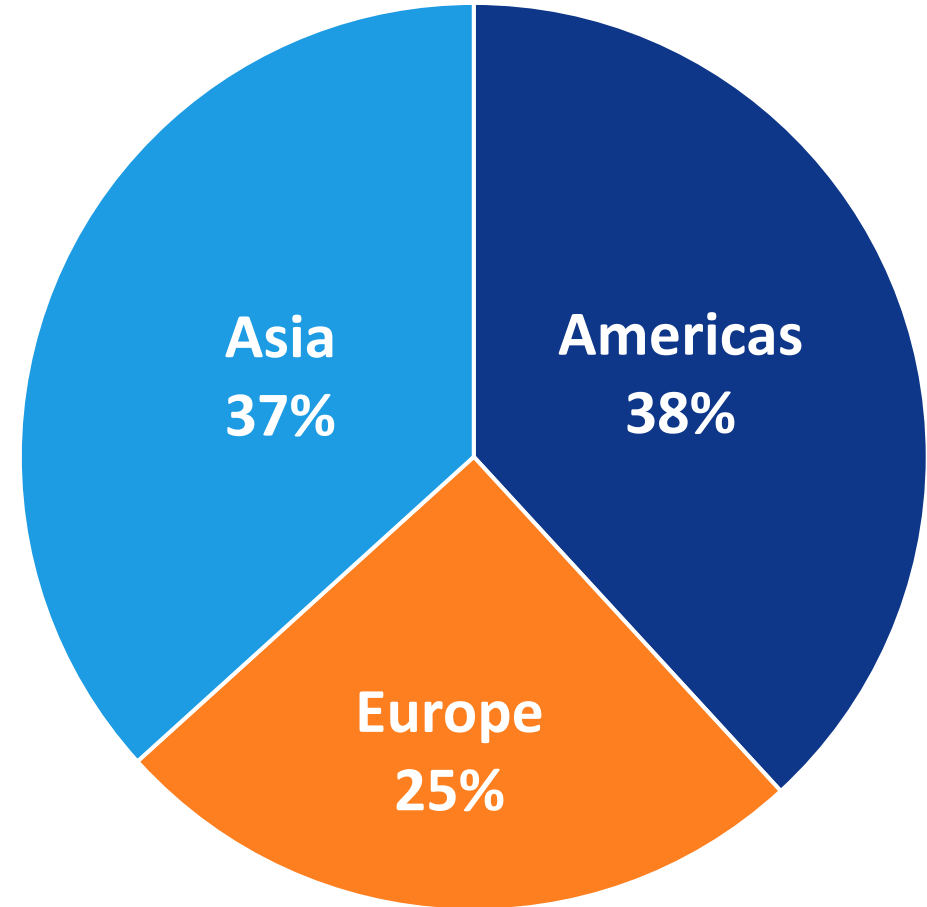

Foundation of Diverse Revenue

Sales Channel Revenue

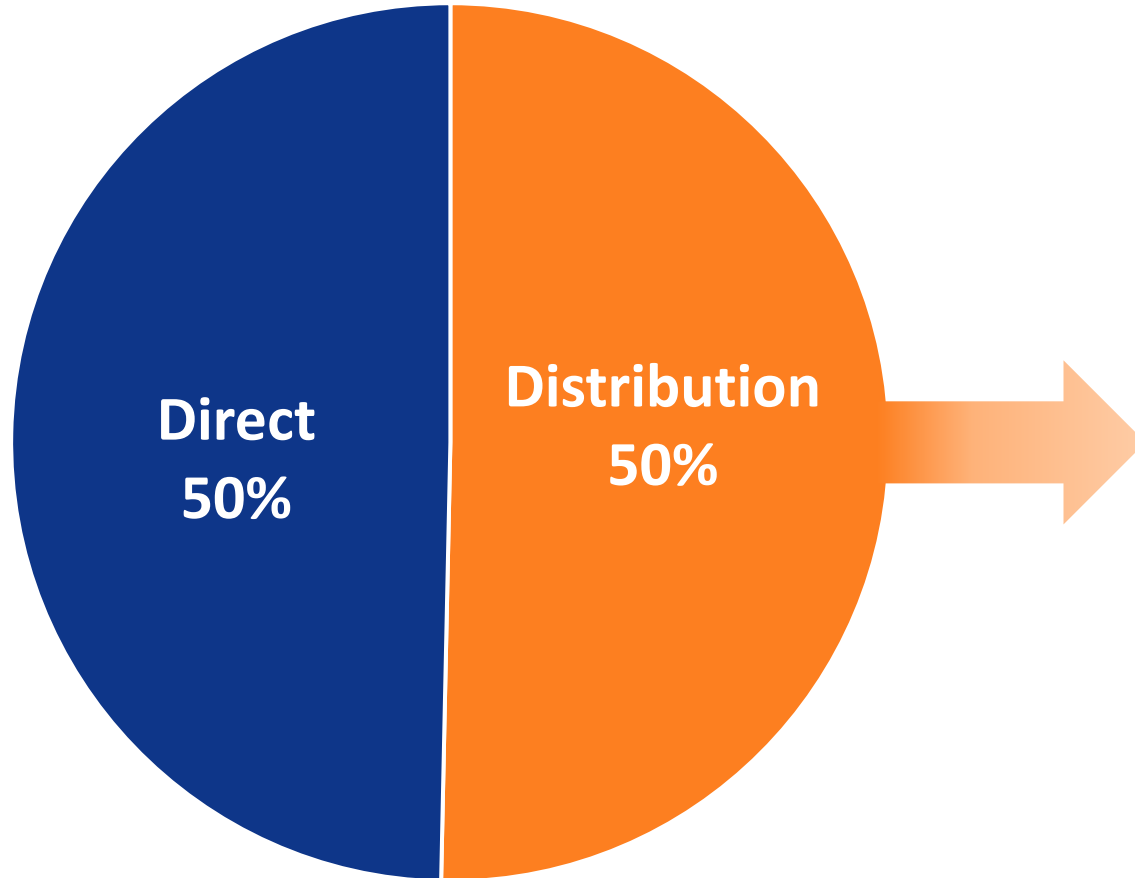

Distribution Revenue

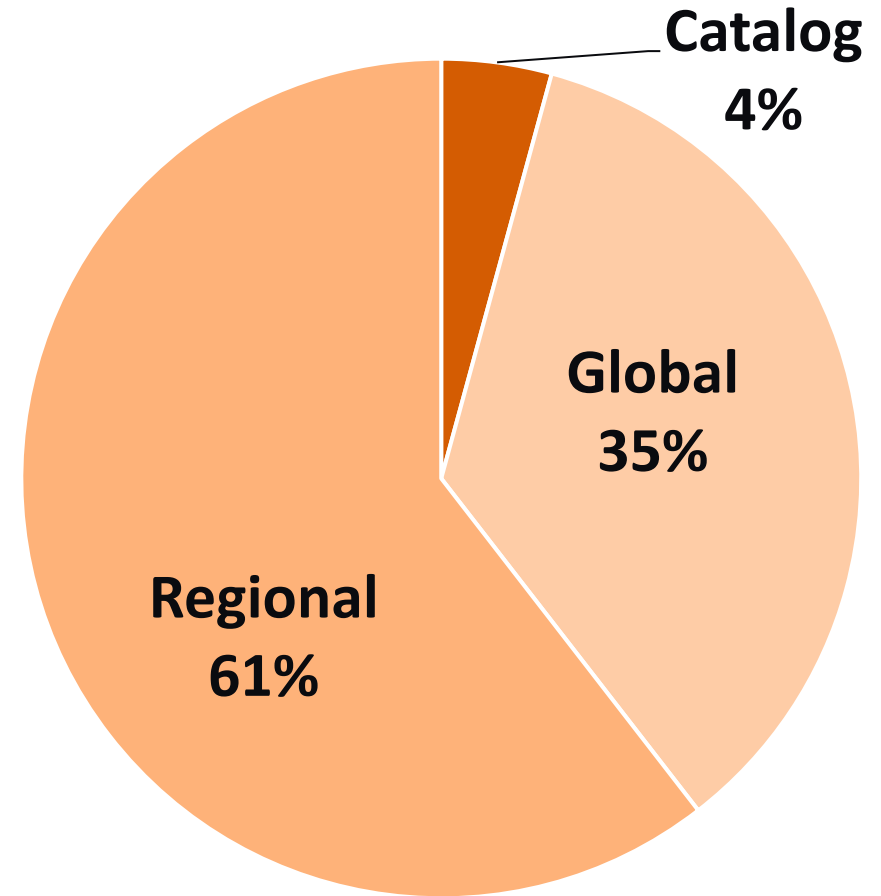

Foundation of Diverse Revenue

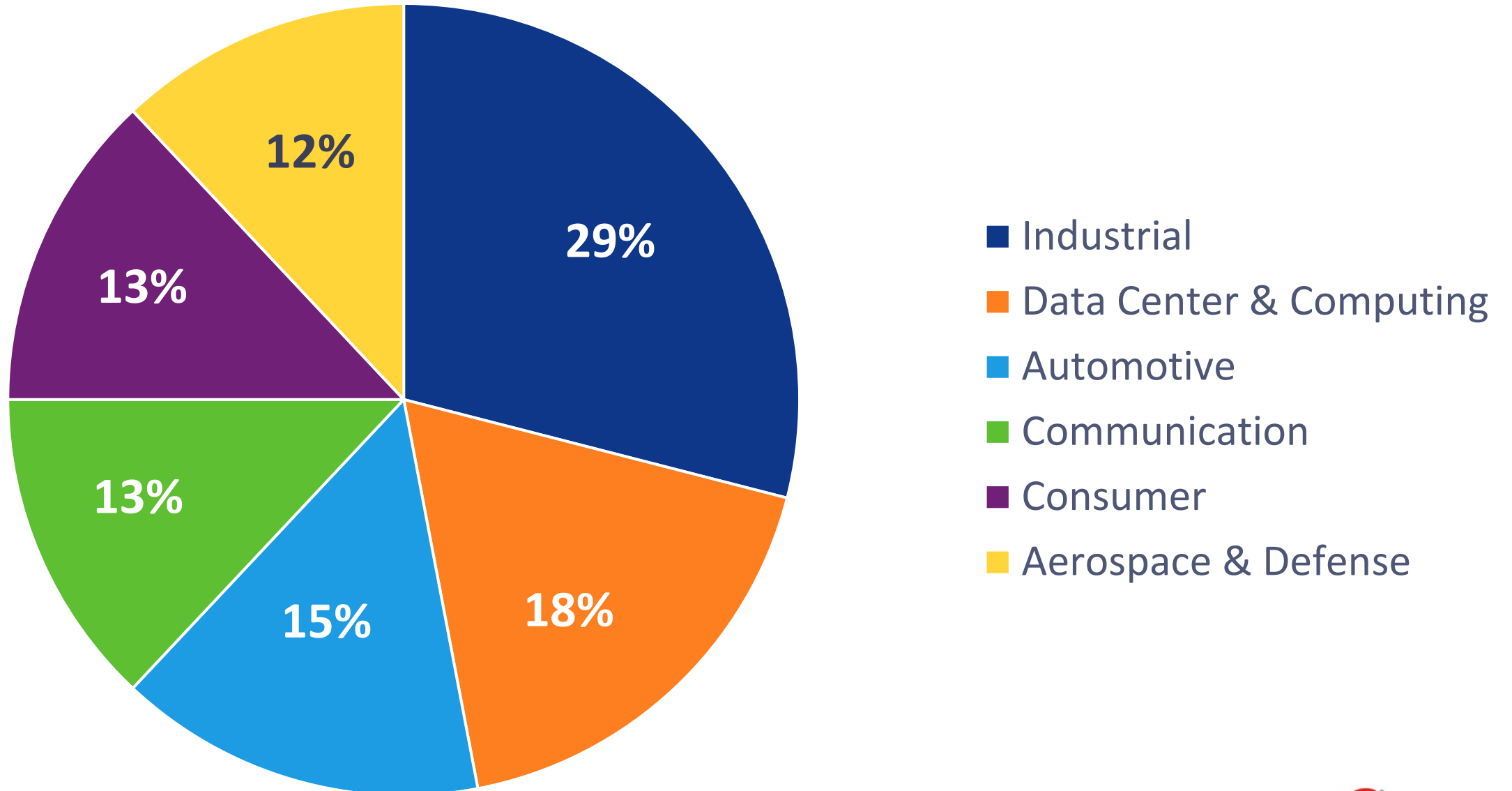

Foundation of Sustainable Revenue

> 120,000 customers

**Sustained customer relationships,
over multiple design generations**

Delivering solutions to all customers

Aligned with Megatrend Growth

Total System Solutions

Record Design-Wins



Customer Engagement Summary

Growing a broad and diverse customer base

Building on a foundation of diverse and sustainable revenue



Enabling Our Growth Strategy

Manufacturing

Mike Finley, SVP of Front-End Operations
Mathew Bunker, SVP of Back-End Operations

2021
Microchip's Investor and Analyst Day

Manufacturing: The Microchip Advantage



Manufacturing Strategy

Strategic relationship with foundries, assembly/test subcontractors, equipment and raw material suppliers

Mix of internal and external manufacturing to give us the right balance of technology, cost and supply

Investment in internal capacity for trailing edge technologies with long remaining life cycles – provides better control and cost

Investment in inventory to optimize cost and customer service enabled by very long-lived products and durable end markets

Environmental stewardship for internal and external manufacturing

Positioned to grow capacity to support 6-8% annual organic growth rate and 67.5-68.5% non-GAAP gross margin

Microchip's Manufacturing Process

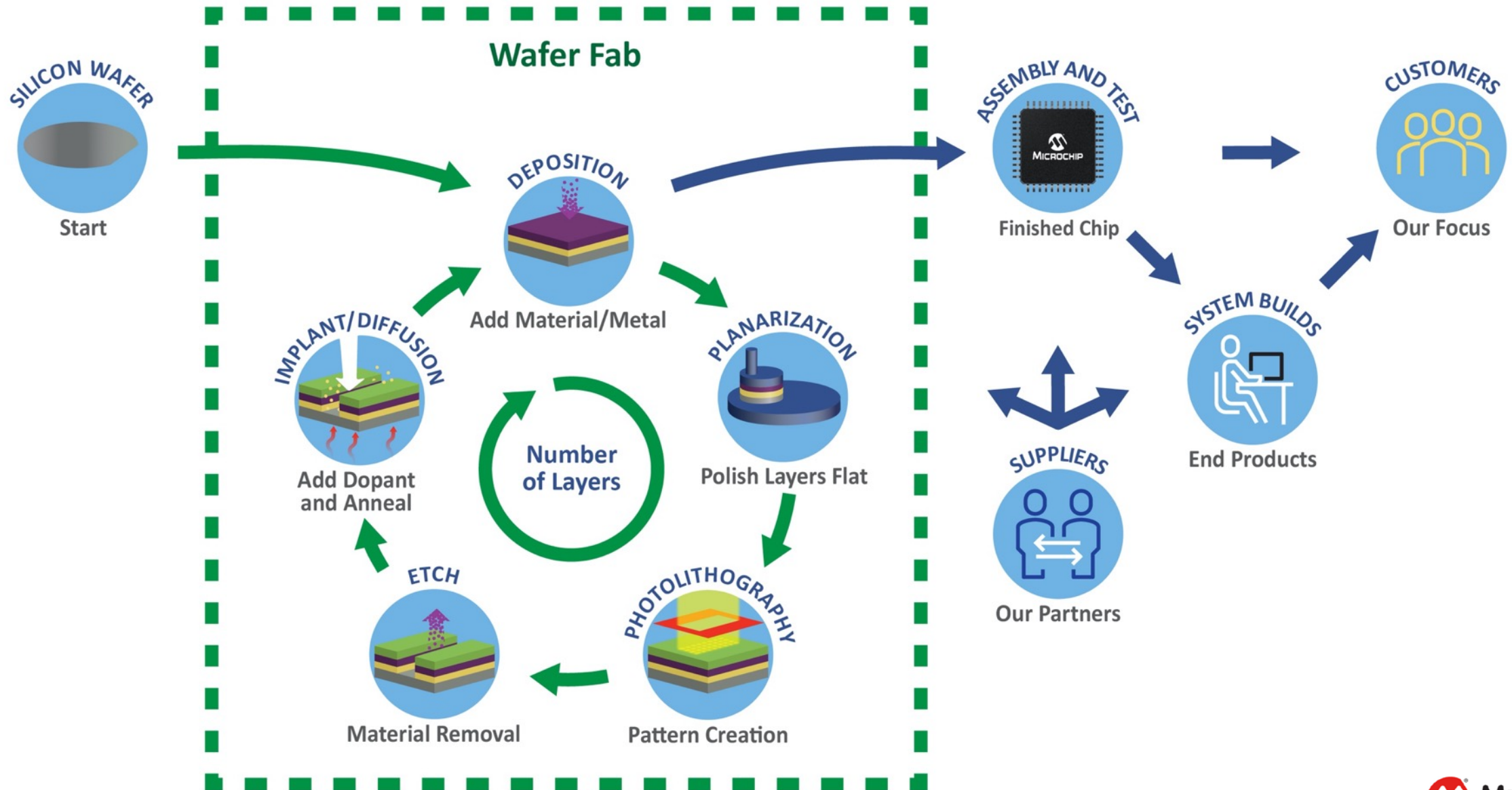

Internal Manufacturing Locations

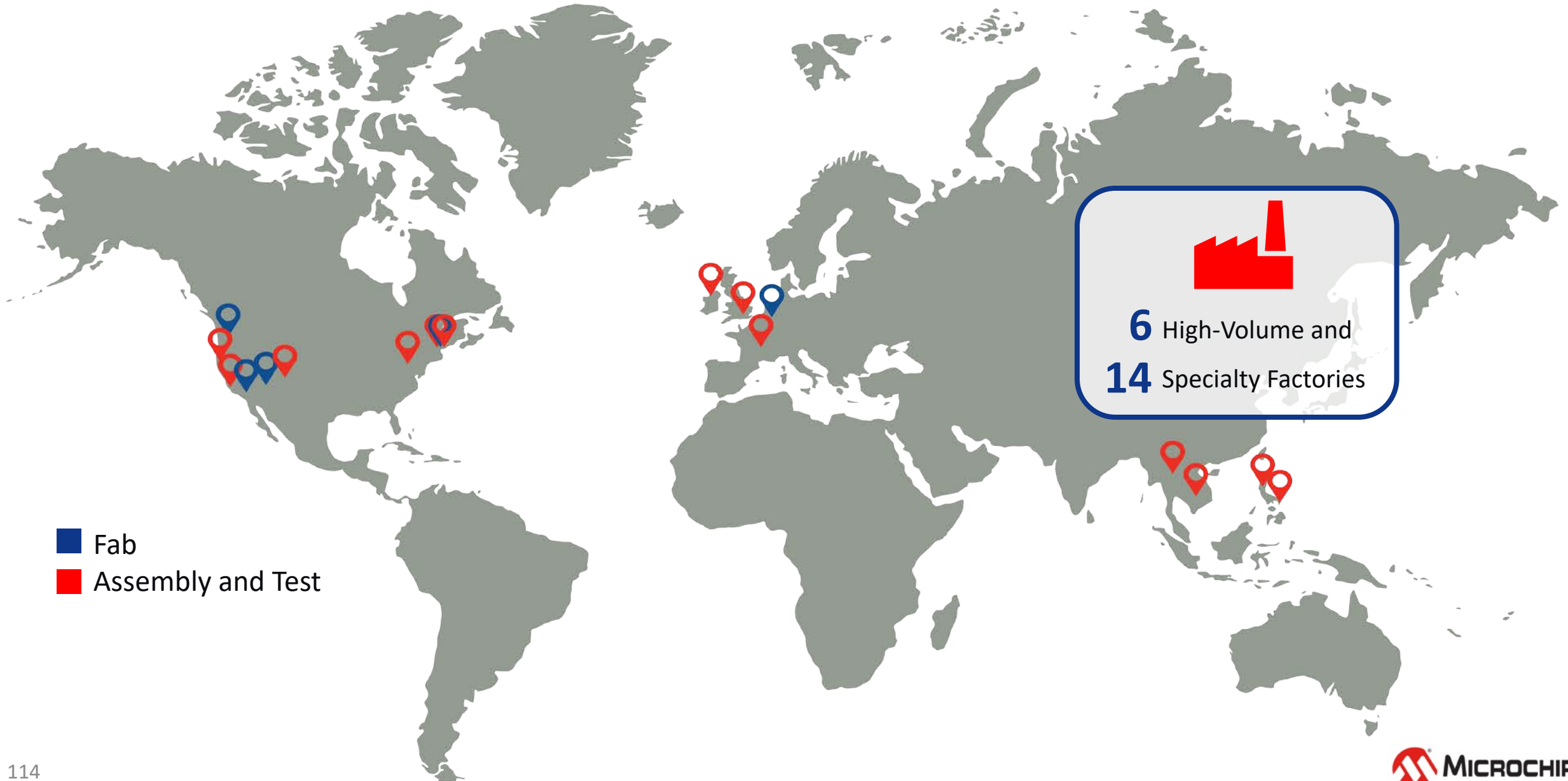

Long Process Technology and Product Life Cycles

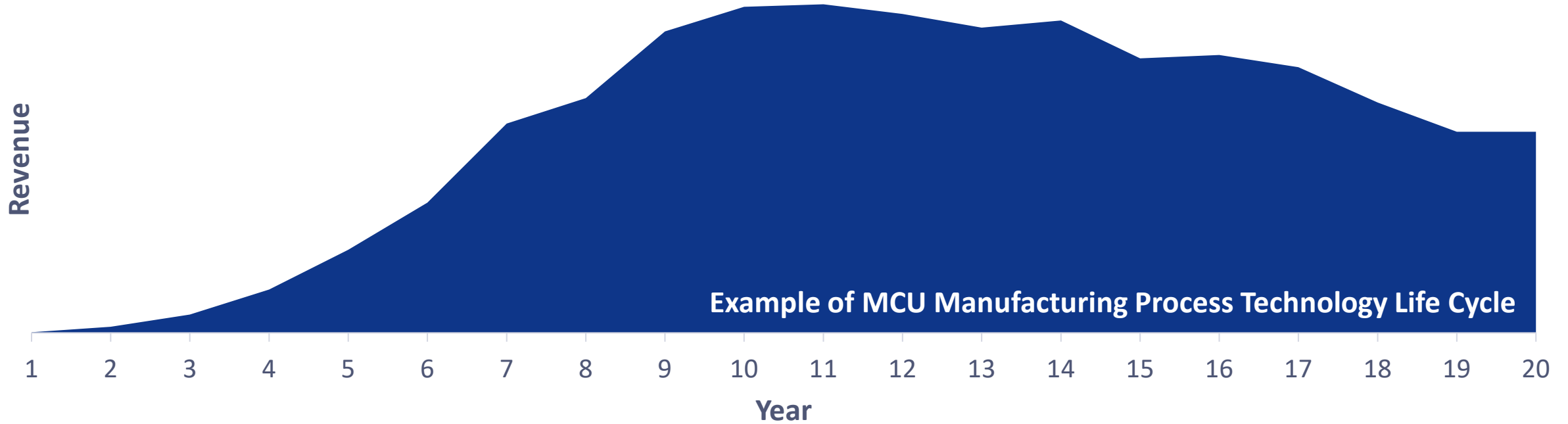

Develop processes and products that deliver revenue for many years

On-going investments in these technologies drive value and customer loyalty

Customer driven obsolescence policy highly valued by customers

Balance of Internal/External Manufacturing

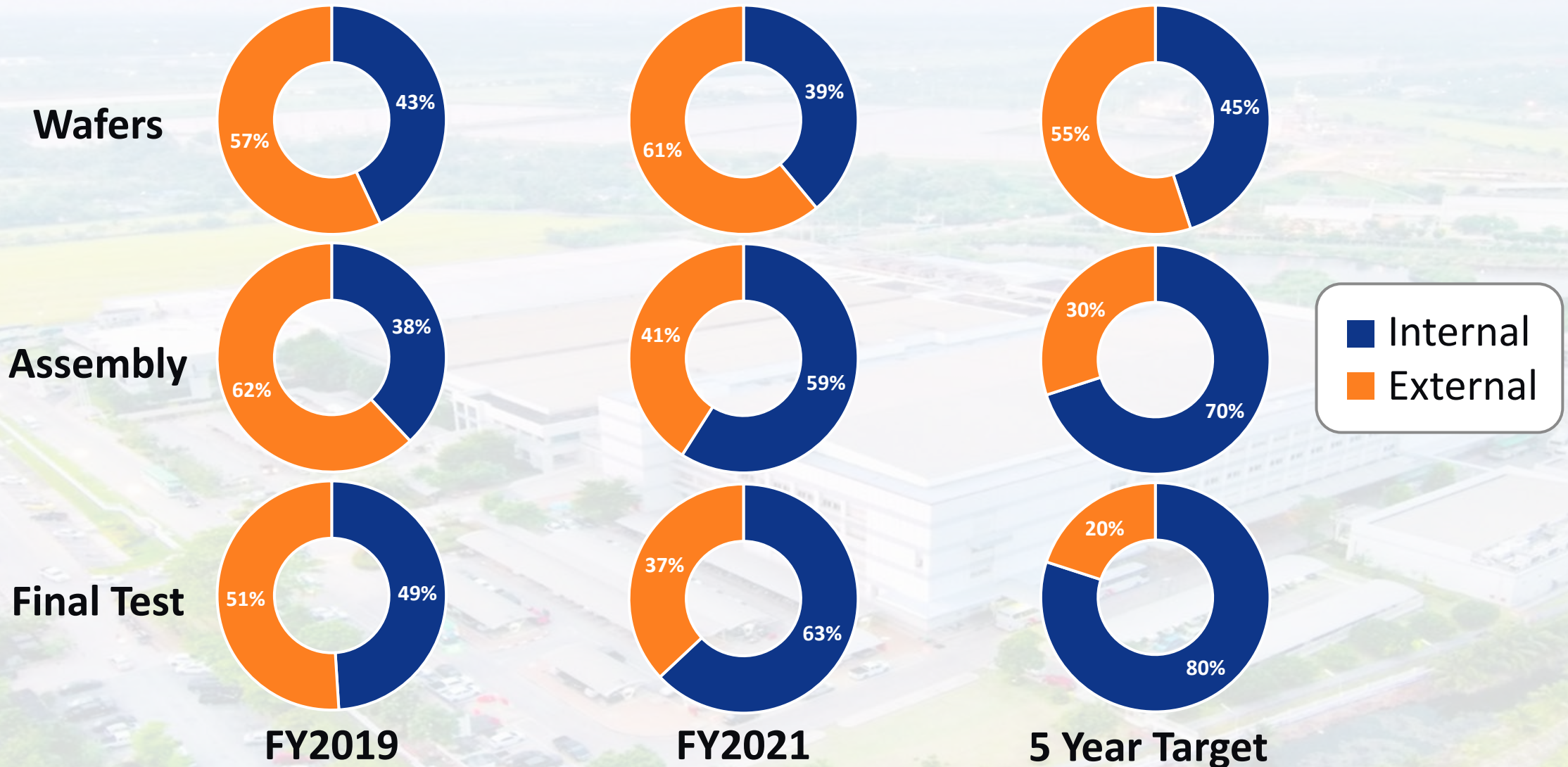

Balance of Internal/External Capacity

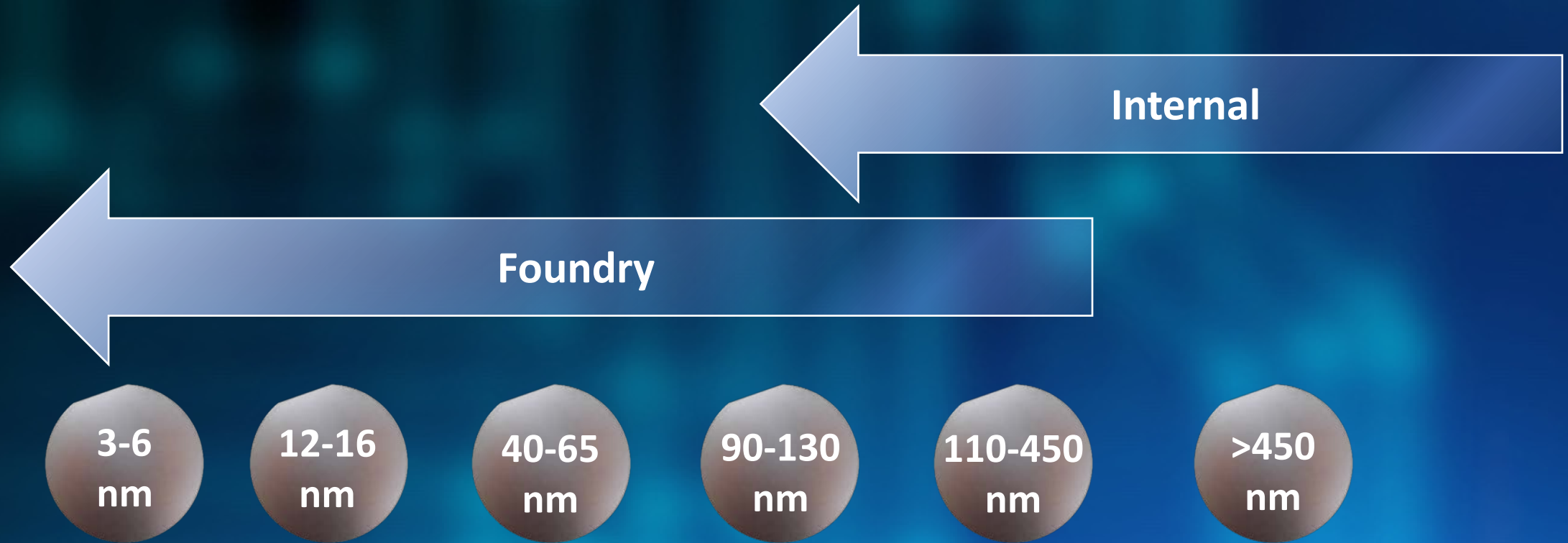

Invest in Inventory

- Long-life products and durable end markets reduce inventory obsolescence risks
- Increasing inventory targets to 130-150 days
 - Enhances ability to service customers
 - More effective use of capital through peaks and troughs that preserves gross margins
 - Happier customers, happier employees, happier investors

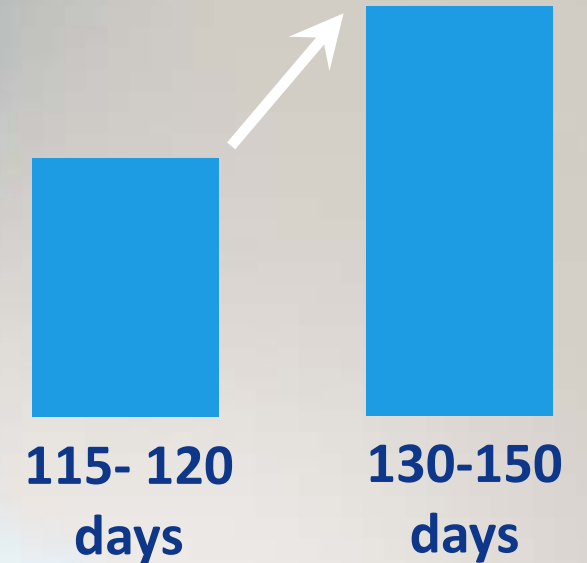

Responsible Growth

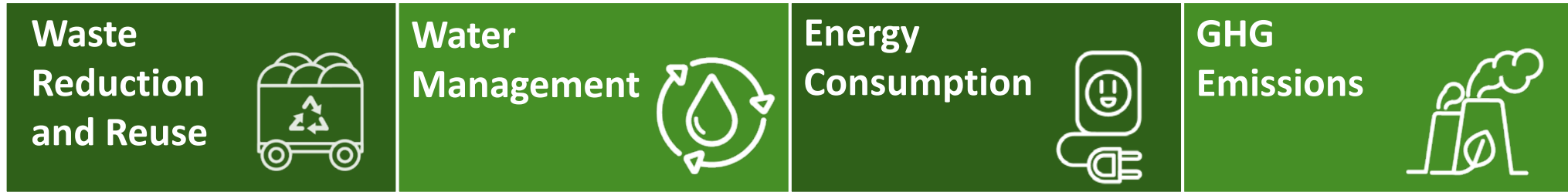

- **Microchip is committed to reducing the environmental impact of our operations and products within the global communities in which we operate and where our products are used**
- **We also contribute to reducing environmental impact by offering a wide array of products that help designers reduce power consumption and make end products more energy efficient.**



Manufacturing Summary

Strategic relationship with foundries, assembly/test subcontractors, equipment and raw material suppliers

Mix of internal and external manufacturing to give us the right balance of technology, cost and supply

Investment in internal capacity for trailing edge technologies with long remaining life cycles – provides better control and cost

Investment in inventory to optimize cost and customer service enabled by very long-lived products and durable end markets

Environmental stewardship for internal and external manufacturing

Positioned to grow capacity to support 6-8% annual organic growth rate and 67.5-68.5% non-GAAP gross margin

Enabling Our Growth Strategy

Sustainability

2021
Microchip's Investor and Analyst Day

Ganesh Moorthy, President & CEO



Sustainability At Microchip

- **Sustainability embeds value generation into business strategy for the long-term benefit of all stakeholders – it's in our DNA**
- **Sustainability strategy incorporates environmental, social and governance (ESG) considerations into important business decisions**
- **SASB framework guides our sustainability journey**
 - Environmental actions focus on reducing water, energy, emission and waste
 - Social actions focus on Diversity, Equity & Inclusion which are already built into our culture and guiding values
- **Total System Solutions enable customers to achieve their environmental goals & multiplies impact of our energy efficiency**
- **Participation in the Responsible Business Alliance facilitates an independent verification that we are meeting our commitments**



NET ZERO BY
2040



Enabling Our Growth Strategy

Culture

2021
Microchip's Investor and Analyst Day

Ganesh Moorthy, President & CEO



Microchip Culture

A Systems Thinking Approach

Inclusion, diversity, and equity are not just words; they are part of our guiding value that Employees to achieve our strategic formula. (Mission) by are our Greatest Strength. It is the way we do aligning and integrating the company's business and ensure our future success. We values, policies, management and employee recognize the power of inclusion, diversity, and practices and human systems to guide our equity to better the lives of our employees and collective strategies, decisions and actions. strengthen the performance of our company.



Culture – An Enduring Competitive Advantage

- Strong, practiced guiding values
- Teamwork trumps prima donnas
- Shared rewards and sacrifices
- Non-commissioned sales force
- Substantial investment in training
- Investment in leadership development and succession planning

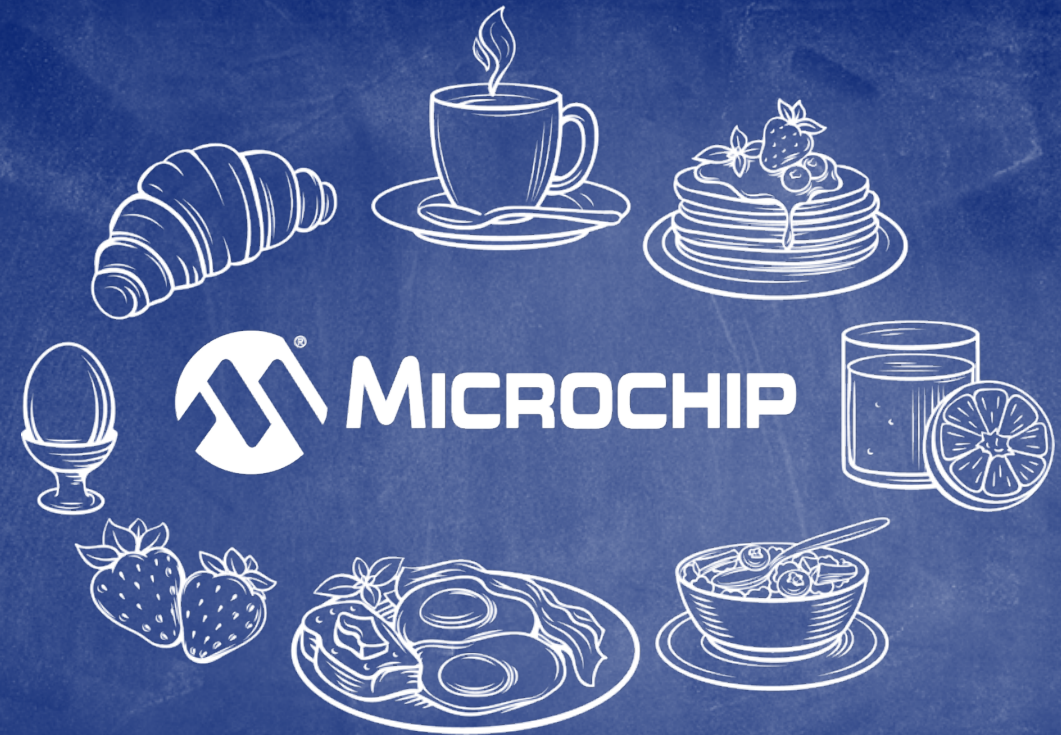

Culture Eats Strategy For Breakfast!! Peter Drucker

Guiding Values

- *Quality comes first*
- *Customers are our focus*
- *Continuous improvement is essential*
- *Employees are our greatest strength*
- *Products and technology are our foundation*
- *Total cycle times are optimized*
- *Safety and security are never compromised*
- *Profits and growth provide for everything we do*
- *Communication is vital*
- *Suppliers, representatives and distributors are our partners*
- *Professional ethics and social responsibility are practiced*

Values are not what we say – they are what we practice!



Guiding Value Means Over Time (Worldwide)

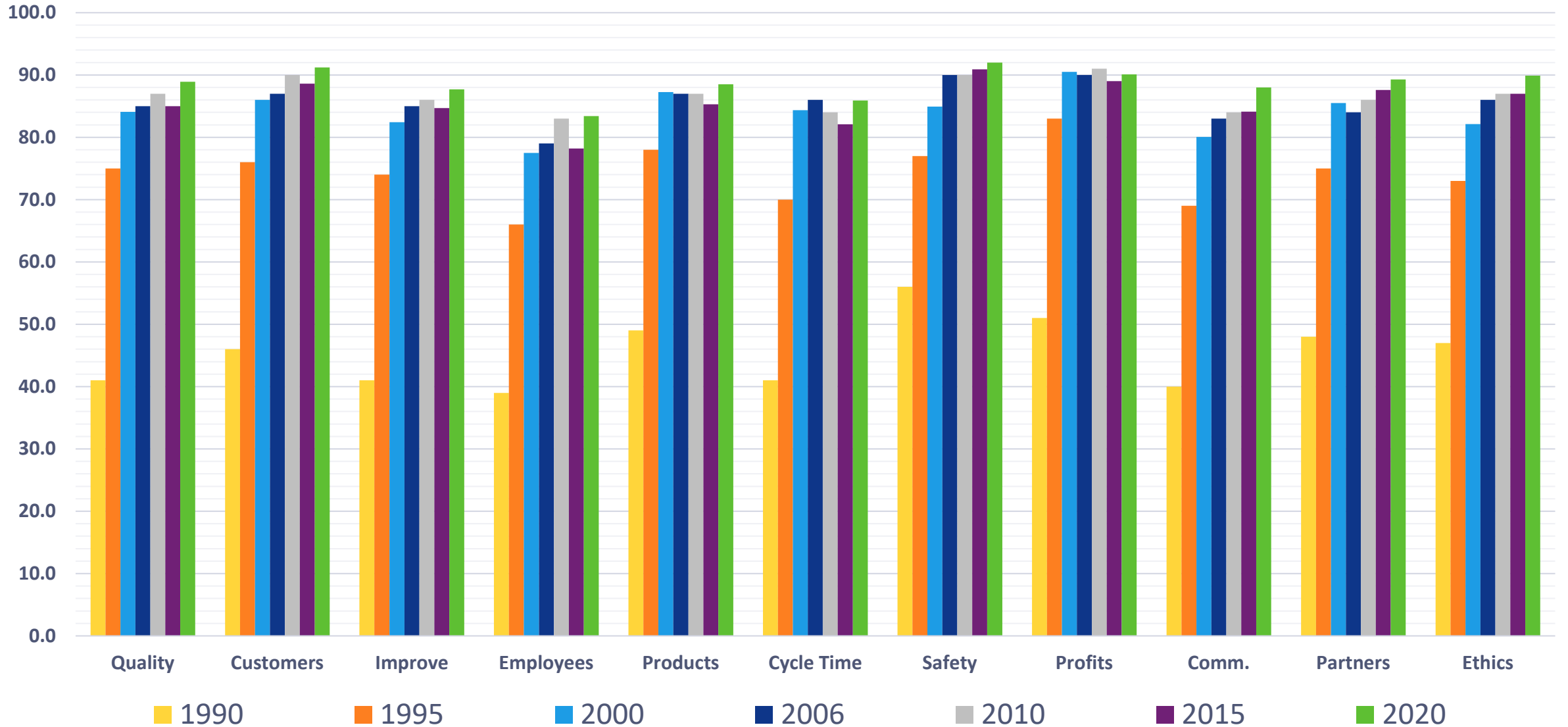

But Don't Take Our Word For It



***“Culture outperforms
strategy every time;
and culture with strategy
is unbeatable.”***



Summary

2021
Microchip's Investor and Analyst Day

Microchip 3.0

Sustained growth from organic efforts focused on TSS and Megatrends

6-8% Organic Revenue CAGR;
~2X industry growth rate*

Elite long-term non-GAAP business model of
67.5% - 68.5% Gross Margin
44% - 46% Operating Margin

EBITDA Margin target of $\geq 48\%$ and FCF target of $\geq 38\%$ of revenue

Diversified end-market mix creates consistent and resilient results

Investment in inventory – 130 - 150 days over business cycles

Investment in capacity for trailing-edge technologies – capital intensity of 3% - 6% of revenue

Increase capital returned to shareholders to 50% of FCF, rising to 100% of FCF as net leverage drops to $\leq 1.5X$

Strong business foundation based on culture and sustainability

Long-Term Non-GAAP Target Model

	1H FY22 Run Rate	Long-Term Target	
Revenue	\$6.4B	6 - 8% CAGR	Grow at ~2X industry growth rate**
Gross Margin	65.0%	67.5% - 68.5%	Continued internalization, manufacturing consolidating, richer product mix and pricing discipline
Operating Expenses	22.9%	22.5% - 23.5%	Operating expense investment to drive growth and high value product mix
Operating Margin	42.1%	44% - 46%	Gross margin improvement drops to operating margin
CAPEX	5.1%	3 - 6 %	Investment in trailing edge technologies
Adjusted EBITDA Margin	45.8%	48%	
Free Cash Flow Margin	33.4%	38%	

* 1H FY22 Run Rate is based on the Company's Q1 and Q2 FY22 non-GAAP results, with revenue multiplied by 2

Microchip's Winning Formula

Grow organically at ~2X industry growth rate while significantly expanding gross and operating margins

Generate significant cash and increase capital returned to owners to 100% of Free Cash Flow

Extend our strong foundation built on culture and sustainability

Our best is still ahead of us!

Thank You!

Empowering Innovation & Delivering Stakeholder Results



SMART | CONNECTED | SECURE

2021
Microchip's Investor and Analyst Day

Appendix

2021
Microchip's Investor and Analyst Day

Non-GAAP Reconciliation

	<u>FY 12</u>	<u>FY 13</u>	<u>FY 14</u>	<u>FY 15</u>	<u>FY 16</u>	<u>FY 17</u>	<u>FY 18</u>	<u>FY 19</u>	<u>FY 20</u>	<u>FY 21</u>	<u>FY 22</u>
Net Sales, as reported*	\$ 1,383.2	\$ 1,581.6	\$ 1,931.2	\$ 2,147.0	\$ 2,173.3	\$ 3,407.8	\$ 3,980.8	\$ 5,349.5	\$ 5,274.2	\$ 5,438.4	\$ 6,624.0
Distributor revenue recognition adjustment	-	24.8	-	13.6	40.5	93.9	-	-	-	-	-
Non-GAAP Net Sales	\$ 1,383.2	\$ 1,606.4	\$ 1,931.2	\$ 2,160.6	\$ 2,213.8	\$ 3,501.7	\$ 3,980.8	\$ 5,349.5	\$ 5,274.2	\$ 5,438.4	\$ 6,624.0
	<u>FY 12</u>	<u>FY 13</u>	<u>FY 14</u>	<u>FY 15</u>	<u>FY 16</u>	<u>FY 17</u>	<u>FY 18</u>	<u>FY 19</u>	<u>FY 20</u>	<u>FY 21</u>	<u>FY 22</u>
Gross Margin, as reported	\$ 799.3	\$ 838.5	\$ 1,128.7	\$ 1,229.6	\$ 1,205.5	\$ 1,757.2	\$ 2,420.7	\$ 2,931.3	\$ 3,242.1	\$ 3,378.8	\$ 4,294.9
Share-based compensation expense	5.6	8.2	7.3	9.0	8.3	18.7	13.8	14.9	20.9	26.6	35.7
Acquisition related	-	-	-	1.8	0.7	3.1	-	0.9	-	-	-
Distributor revenue recognition adjustment	-	15.9	-	6.4	23.8	50.3	-	-	-	-	-
Manufacturing excursion	-	-	-	-	3.6	(0.5)	(0.6)	-	-	5.8	-
Excess capacity charges to normalize acquired inventory levels	-	-	-	-	-	-	-	2.3	-	-	-
Acquired inventory valuation costs	-	56.0	0.4	24.4	44.9	186.7	-	365.7	-	-	-
COVID-19 shelter-in-place restrictions	-	-	-	-	-	-	-	-	3.3	2.8	-
Non-GAAP Gross Margin	\$ 804.9	\$ 918.6	\$ 1,136.4	\$ 1,271.1	\$ 1,286.8	\$ 2,015.5	\$ 2,433.9	\$ 3,315.0	\$ 3,266.4	\$ 3,414.0	\$ 4,330.7
Non-GAAP Gross Margin Percentage of Non-GAAP Net Sales	58.2%	57.2%	58.8%	58.8%	58.1%	57.6%	61.1%	62.0%	61.9%	62.8%	65.4%
	<u>FY 12</u>	<u>FY 13</u>	<u>FY 14</u>	<u>FY 15</u>	<u>FY 16</u>	<u>FY 17</u>	<u>FY 18</u>	<u>FY 19</u>	<u>FY 20</u>	<u>FY 21</u>	<u>FY 22</u>
Operating Income, as reported	\$ 396.5	\$ 178.6	\$ 458.9	\$ 425.6	\$ 352.3	\$ 275.8	\$ 936.3	\$ 714.3	\$ 647.1	\$ 998.1	\$ 1,683.6
Share-based compensation expense	38.3	58.0	53.8	58.6	71.5	128.1	93.2	149.2	170.2	198.3	222.9
Acquisition-related restructuring and other costs	0.8	7.3	2.7	5.8	10.4	31.0	10.1	44.1	35.8	4.0	20.1
Distributor revenue recognition adjustment	-	15.9	-	6.4	23.8	50.3	-	-	-	-	-
Manufacturing excursion	-	-	-	-	3.6	(0.5)	(0.6)	-	-	5.8	-
Excess capacity charges to normalize acquired inventory levels	-	-	-	-	-	-	-	2.3	-	-	-
Acquired inventory valuation costs	-	56.0	0.4	24.4	44.9	186.7	-	365.7	-	-	-
COVID-19 shelter-in-place restrictions	-	-	-	-	-	-	-	-	3.3	2.8	-
Amortization of acquired intangible assets	11.0	111.5	94.5	176.7	174.9	337.7	485.5	674.1	993.9	932.3	862.7
Special charges	0.8	32.2	3.0	2.8	4.0	98.6	17.5	33.7	46.7	1.7	27.6
IT security remediation	-	-	-	-	-	-	-	-	6.8	1.5	-
Professional services - certain legal matters	-	-	-	-	-	-	-	-	3.3	9.5	5.1
Non-GAAP Operating Income	\$ 447.4	\$ 459.5	\$ 613.2	\$ 700.4	\$ 685.4	\$ 1,107.7	\$ 1,542.0	\$ 1,983.4	\$ 1,907.2	\$ 2,153.9	\$ 2,822.0
Non-GAAP Operating Income Percentage of Non-GAAP Net Sales	32.3%	28.6%	31.8%	32.4%	31.0%	31.6%	38.7%	37.1%	36.2%	39.6%	42.6%

*In FY19, the Company adopted ASC 606, which requires revenue to be recognized when control of the product changes from us to a customer or distributor. Prior to FY19, Net Sales was reported on a sell-through basis, when our distributors sold the inventory to the end customer. Non-GAAP adjustments represent changes in distributor revenue recognition related to our acquisitions.

Non-GAAP Reconciliation

	<u>FY 12</u>	<u>FY 13</u>	<u>FY 14</u>	<u>FY 15</u>	<u>FY 16</u>	<u>FY 17</u>	<u>FY 18</u>	<u>FY 19</u>	<u>FY 20</u>	<u>FY 21</u>	<u>Q1</u>	<u>Q2</u>	<u>FY 22</u>
Net cash provided by operations, as reported	\$ 412.0	\$ 459.4	\$ 676.6	\$ 721.2	\$ 744.4	\$ 1,059.5	\$ 1,419.6	\$ 1,674.8	\$ 1,543.8	\$ 1,916.5	\$ 629.9	\$ 611.7	\$ 2,559.5
Capital expenditures	(62.4)	(50.8)	(113.1)	(149.5)	(97.9)	(75.3)	(206.8)	(228.9)	(67.6)	(92.6)	(86.3)	(78.5)	(326.4)
Free Cash Flow	\$ 349.6	\$ 408.6	\$ 563.5	\$ 571.7	\$ 646.5	\$ 984.2	\$ 1,212.8	\$ 1,445.9	\$ 1,476.2	\$ 1,823.9	\$ 543.6	\$ 533.2	\$ 2,233.1
Free Cash Flow Percentage of Non-GAAP Net Sales	25.3%	25.4%	29.2%	26.5%	29.2%	28.1%	30.5%	27.0%	28.0%	33.5%	34.6%	32.3%	33.7%

Net Debt*

	Q1FY19	Q2FY19	Q3FY19	Q4FY19	Q1FY20	Q2FY20	Q3FY20	Q4FY20	Q1FY21	Q2FY21	Q3FY21	Q4FY21	Q1FY22	Q2FY22
<i>Senior Indebtedness</i>														
Revolving Credit Facility	\$ 3,334.0	\$ 3,100.0	\$ 2,742.5	\$ 3,266.5	\$ 3,197.0	\$ 2,881.5	\$ 2,624.5	\$ 2,388.5	\$ 1,454.6	\$ 1,919.6	\$ 2,356.6	\$ 2,346.6	\$ 1,958.6	\$ 1,806.6
Term Loan Facility	3,000.0	2,733.0	2,713.0	1,911.5	1,723.5	1,723.5	1,723.5	1,723.5	1,705.7	1,705.7	-	-	-	-
Bridge Loan				-	-	-	-	615.0	-	-	-	-	-	-
2023 Notes	1,000.0	1,000.0	1,000.0	1,000.0	1,000.0	1,000.0	1,000.0	1,000.0	1,000.0	1,000.0	1,000.0	1,000.0	1,000.0	1,000.0
2021 Notes	1,000.0	1,000.0	1,000.0	1,000.0	1,000.0	1,000.0	1,000.0	1,000.0	1,000.0	1,000.0	1,000.0	1,000.0	-	-
2023 Notes	-	-	-	-	-	-	-	-	1,000.0	1,000.0	1,000.0	1,000.0	1,000.0	1,000.0
2024 Notes	-	-	-	-	-	-	-	-	-	-	1,400.0	1,400.0	1,400.0	1,400.0
2024 Notes	-	-	-	-	-	-	-	-	-	-	-	-	1,000.0	1,000.0
2025 Notes	-	-	-	-	-	-	-	-	1,200.0	1,200.0	1,200.0	1,200.0	1,200.0	1,200.0
Total Senior Indebtedness	8,334.0	7,833.0	7,455.5	7,178.0	6,920.5	6,605.0	6,348.0	6,727.0	7,360.3	7,825.3	7,956.6	7,946.6	7,558.6	7,406.6
<i>Senior Subordinated Convertible Debt</i>														
2024 Senior Convertible Debt	-	-	-	-	-	-	-	-	-	-	665.5	665.5	665.5	665.5
2025 Senior Convertible Debt	1,725.0	1,725.0	1,725.0	1,725.0	1,725.0	1,725.0	1,725.0	1,110.0	726.7	312.4	222.4	141.4	141.4	71.0
2027 Senior Convertible Debt	2,070.0	2,070.0	2,070.0	2,070.0	2,070.0	2,070.0	2,070.0	2,070.0	1,426.1	1,044.3	455.5	333.3	333.3	232.6
<i>Junior Subordinated Convertible Debt</i>														
2037 Junior Convertible Debt	686.3	686.3	686.3	686.3	686.3	686.3	686.3	686.3	686.3	686.3	278.6	122.6	122.6	30.1
Total Convertible Debt	4,481.3	4,481.3	4,481.3	4,481.3	4,481.3	4,481.3	4,481.3	3,866.3	2,839.1	2,043.0	1,622.0	1,262.8	1,262.8	999.2
Total Gross Debt	\$ 12,815.3	\$ 12,314.3	\$ 11,936.8	\$ 11,659.3	\$ 11,401.8	\$ 11,086.3	\$ 10,829.3	\$ 10,593.3	\$ 10,199.4	\$ 9,868.3	\$ 9,578.6	\$ 9,209.4	\$ 8,821.4	\$ 8,405.8
Cash and short-term investments	\$ 649.7	\$ 464.2	\$ 436.2	\$ 430.9	\$ 437.1	\$ 405.1	\$ 402.3	\$ 403.0	\$ 380.2	\$ 370.3	\$ 372.7	\$ 282.0	\$ 279.7	\$ 255.3
Net Debt	\$ 11,479.3	\$ 11,163.8	\$ 10,814.3	\$ 10,542.1	\$ 10,278.4	\$ 9,994.9	\$ 9,740.7	\$ 9,504.0	\$ 9,132.9	\$ 8,811.7	\$ 8,927.3	\$ 8,804.8	\$ 8,419.1	\$ 8,120.4

Adjusted EBITDA*

	FY 12	FY 13	FY 14	FY 15	FY 16	FY 17	FY 18	FY 19	FY 20	FY 21	FY 22
Net income, as reported	\$ 336.7	\$ 127.4	\$ 395.3	\$ 369.0	\$ 324.1	\$ 164.6	\$ 255.4	\$ 355.9	\$ 570.6	\$ 349.4	\$ 1,105.3
Discontinued operations, net	-	-	-	-	-	6.0	-	-	-	-	-
Noncontrolling interests	-	-	-	(3.7)	(0.2)	-	-	-	-	-	-
Interest expense	34.3	40.9	48.7	62.0	104.0	146.3	199.0	502.9	497.3	356.9	267.7
Income tax (benefit) expense	43.0	24.8	37.1	(19.4)	(42.6)	(80.8)	481.9	(151.4)	(420.2)	(9.9)	194.4
Depreciation	86.4	88.3	89.7	97.3	103.8	122.9	123.7	180.6	168.9	160.6	174.4
Amortization	13.0	115.8	99.4	181.0	179.3	346.3	492.2	695.8	1,046.7	992.7	932.5
Special charges and other, net	0.8	32.2	3.0	2.8	4.0	98.6	17.5	16.5	46.7	1.7	27.6
Share based compensation expense	38.3	58.0	53.8	58.6	71.4	128.2	93.2	166.7	170.2	198.3	222.9
Non-cash losses, charges or expenses	-	-	-	-	23.8	50.3	-	-	-	-	-
Acquisition related and non-operating expenses and income	-	56.0	0.7	24.7	48.6	217.3	10.8	409.7	49.2	23.6	25.0
Other loss (income)	0.4	0.4	(5.9)	(13.7)	(8.9)	(1.3)	5.8	2.2	(3.2)	3.8	2.8
Interest income	(12.4)	(15.6)	(16.5)	(19.5)	(24.4)	(3.1)	(22.0)	(8.1)	(2.8)	(1.7)	(0.8)
Losses on equity method investments	0.2	0.6	0.2	0.3	0.3	0.2	0.2	0.2	-	-	-
Pre-acquisition Adjusted EBITDA of acquired companies	-	-	-	-	-	-	-	28.6	-	-	-
Loss on settlement of debt	-	-	-	50.6	-	43.9	16.0	12.6	5.4	299.6	114.0
Adjusted EBITDA	\$ 540.7	\$ 528.9	\$ 705.5	\$ 790.1	\$ 783.2	\$ 1,239.3	\$ 1,673.7	\$ 2,212.2	\$ 2,128.8	\$ 2,375.0	\$ 3,065.9
Adjusted EBITDA Percentage of Non-GAAP Net Sales	39.1%	32.9%	36.5%	36.6%	35.4%	35.4%	42.0%	41.4%	40.4%	43.7%	46.3%

*Adjusted EBITDA is as defined in the Company's Amended and Restated Credit Agreement dated as of March 21, 2020 and includes the pre-acquisition Adjusted EBITDA of Microsemi in Fiscal 19.