

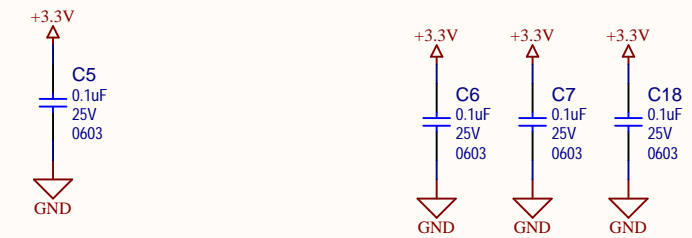

REV	ECO#	DESCRIPTION	DATE

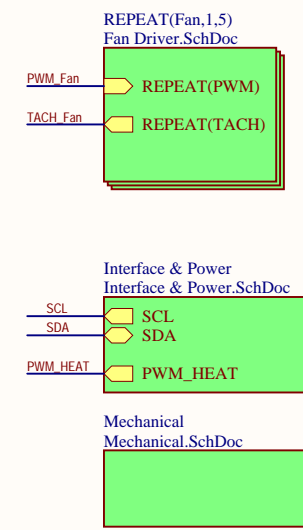

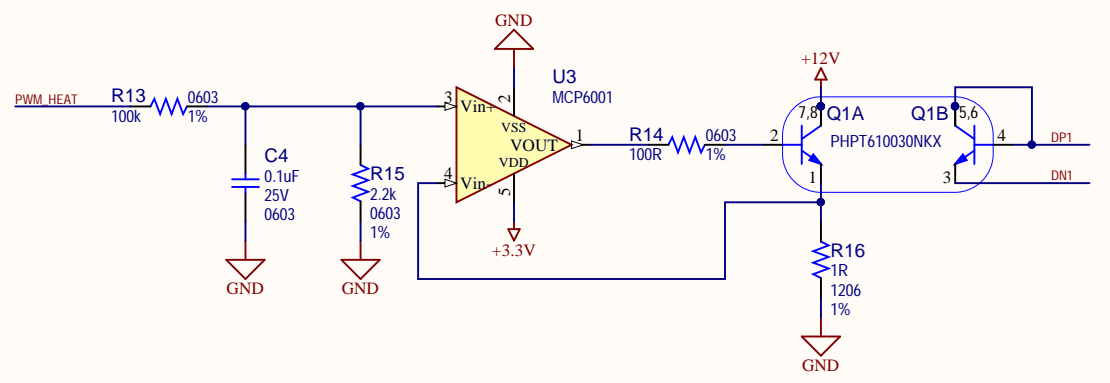
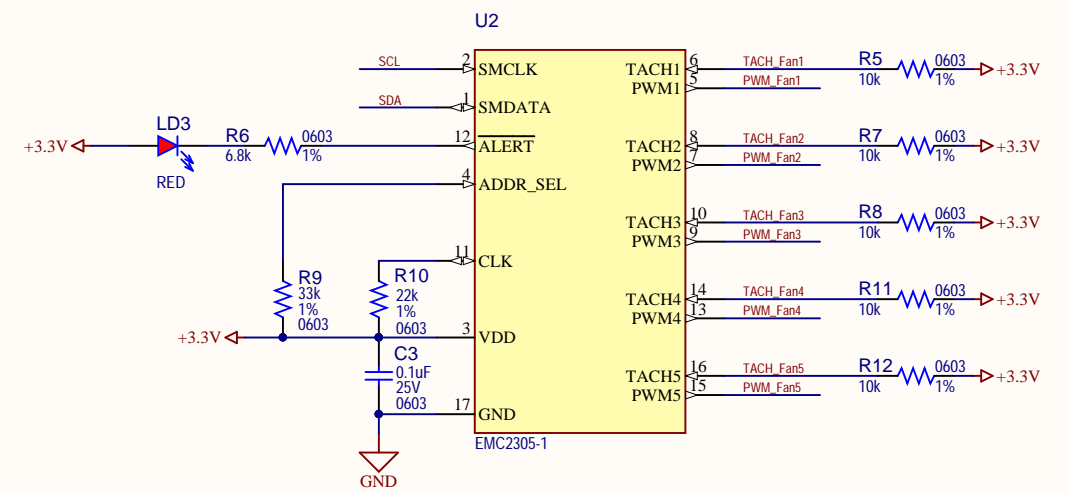
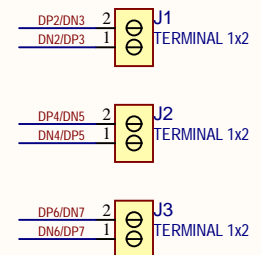
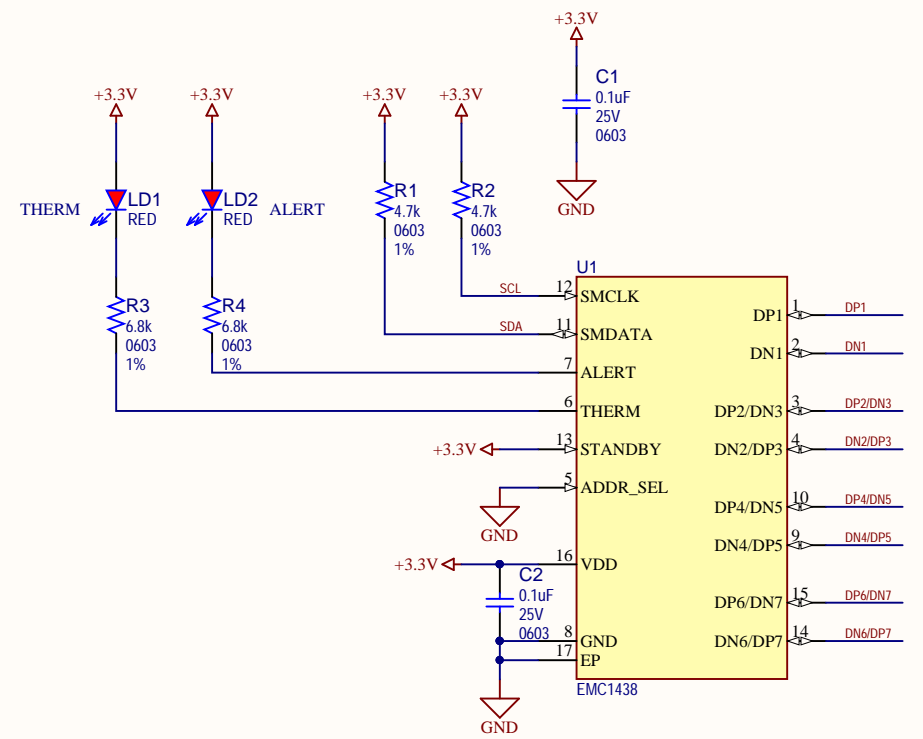
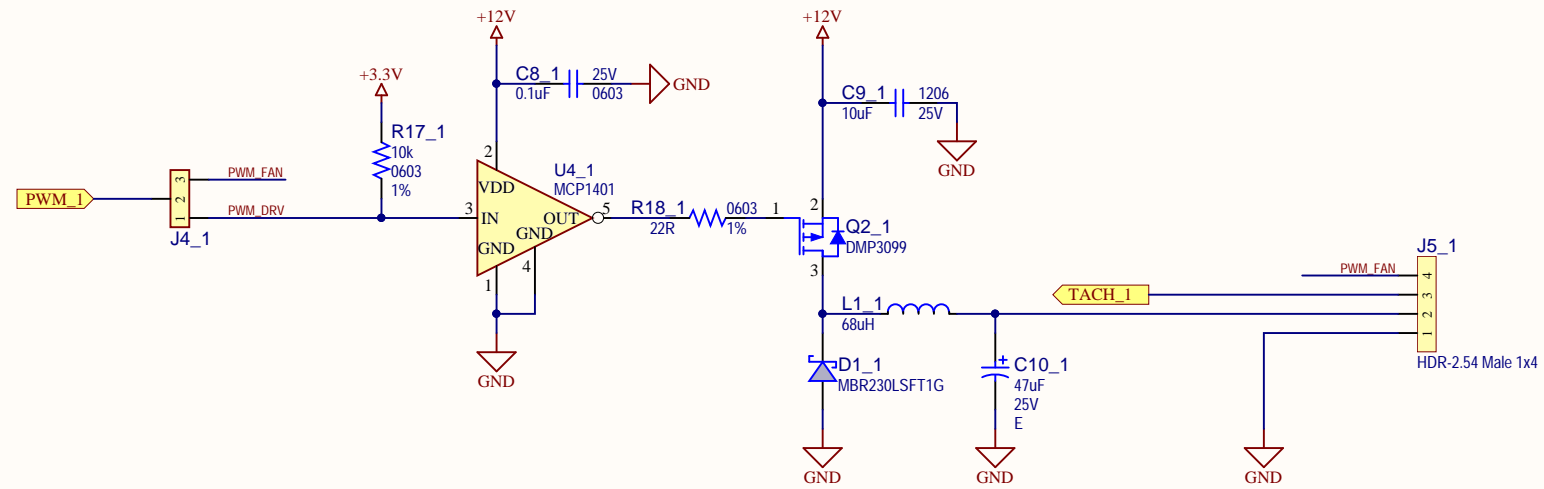

Drawn By: Bogdan Popescu	
Engineer: Bogdan Popescu	
PartNumber: ADM00879	Project Title EMC2305 & EMC1438 Fan Controller Demo
Sheet Title EMC2305 & EMC1438	Designed with
Size B	Sch #03-10737 Revision:3
Date: 10/18/2018 11:33:24 AM	Sheet 1 of 4
File: EMC2305 & EMC1438.SchDoc	



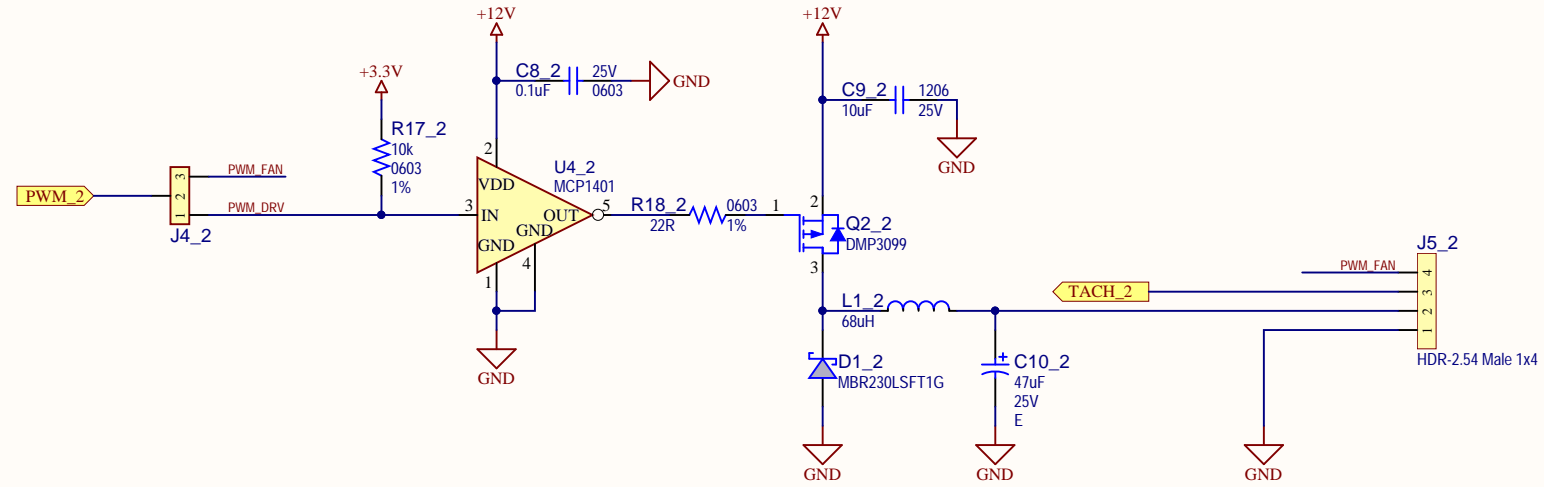

Drawn By: Bogdan Popescu		
Engineer: Bogdan Popescu		
PartNumber: ADM00879	Project Title EMC2305 & EMC1438 Fan Controller Demo	
Sheet Title Fan Driver		 <small>Designed with</small> <small>Altium.com</small>
Size B	Sch #03-10737	Date: 10/18/2018 11:33:24 AM
Revision:3		Sheet 2 of 4
File: Fan Driver.SchDoc		



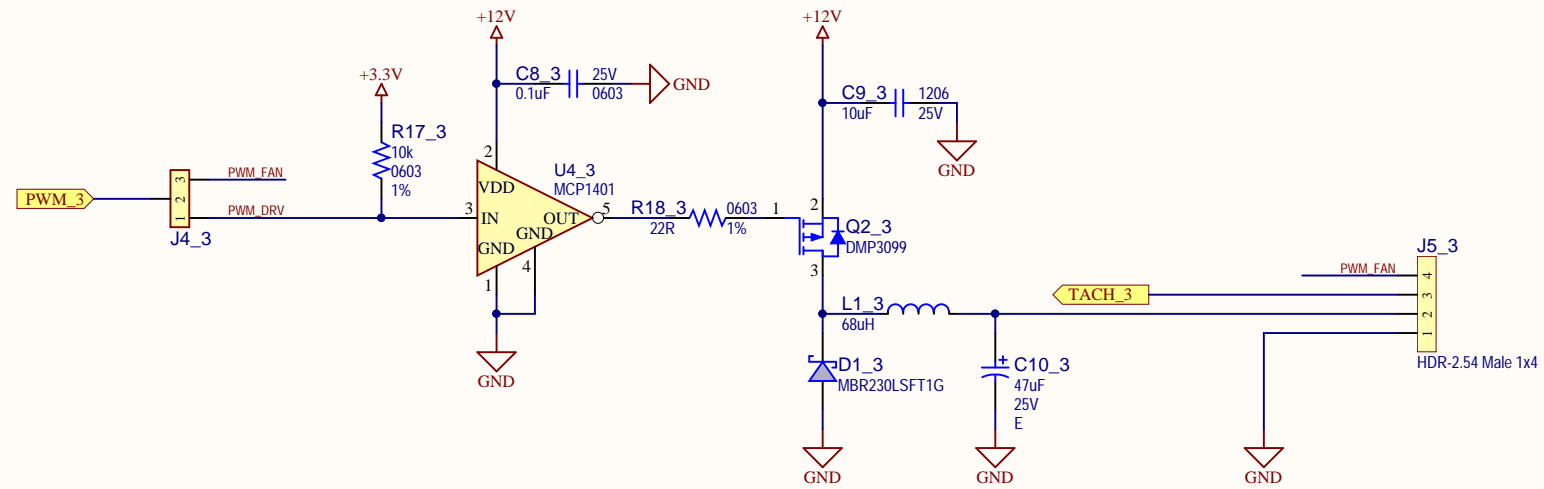

Drawn By: Bogdan Popescu		
Engineer: Bogdan Popescu		
PartNumber: ADM00879	Project Title EMC2305 & EMC1438 Fan Controller Demo	
Sheet Title Fan Driver		Designed with 
Size B	Sch #03-10737	Date: 10/18/2018 11:33:24 AM
	Revision:3	Sheet 2 of 4
File: Fan Driver.SchDoc		

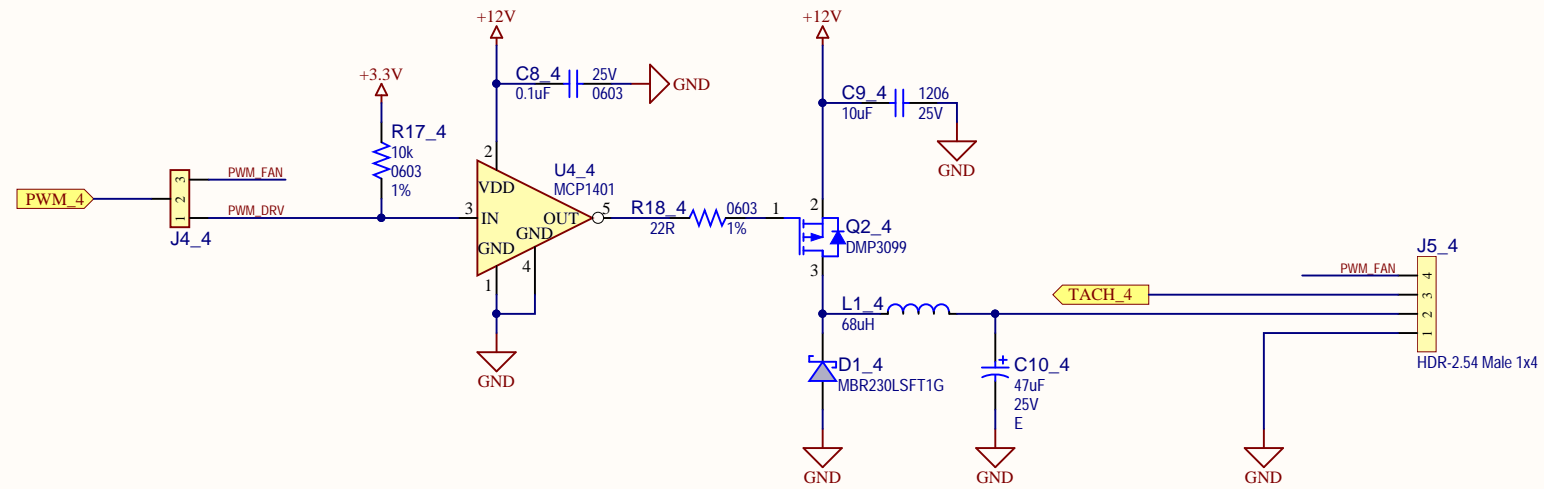

Drawn By: Bogdan Popescu		
Engineer: Bogdan Popescu		
PartNumber: ADM00879	Project Title EMC2305 & EMC1438 Fan Controller Demo	
Sheet Title Fan Driver		Designed with 
Size B	Sch #03-10737	Date: 10/18/2018 11:33:24 AM
	Revision:3	Sheet 2 of 4
File: Fan Driver.SchDoc		



Drawn By: Bogdan Popescu			
Engineer: Bogdan Popescu			
PartNumber: ADM00879	Project Title EMC2305 & EMC1438 Fan Controller Demo		
Sheet Title Fan Driver			
Size B	Sch #03-10737	Date: 10/18/2018 11:33:25 AM	
	Revision:3	Sheet 2 of 4	
File: Fan Driver.SchDoc			

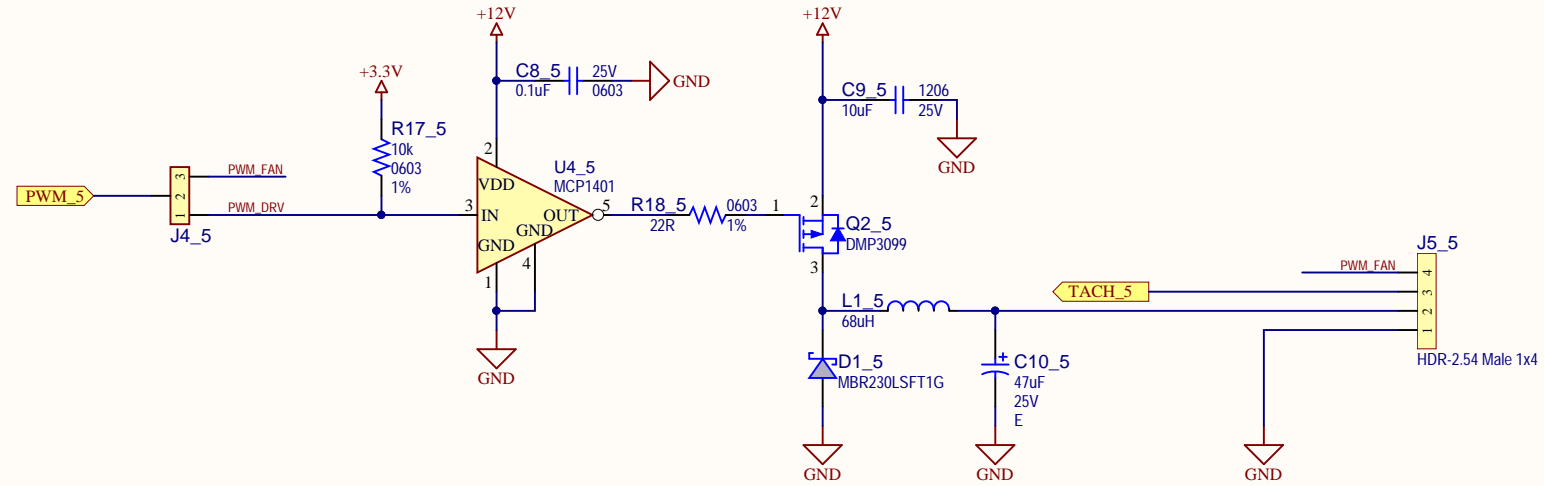

Drawn By: Bogdan Popescu		
Engineer: Bogdan Popescu		
PartNumber: ADM00879	Project Title EMC2305 & EMC1438 Fan Controller Demo	
Sheet Title Fan Driver		Designed with
Size B	Sch #03-10737	Date: 10/18/2018 11:33:25 AM
	Revision:3	Sheet 2 of 4
File: Fan Driver.SchDoc		

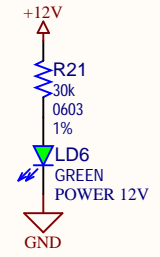
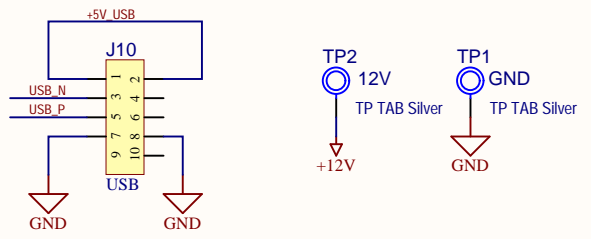
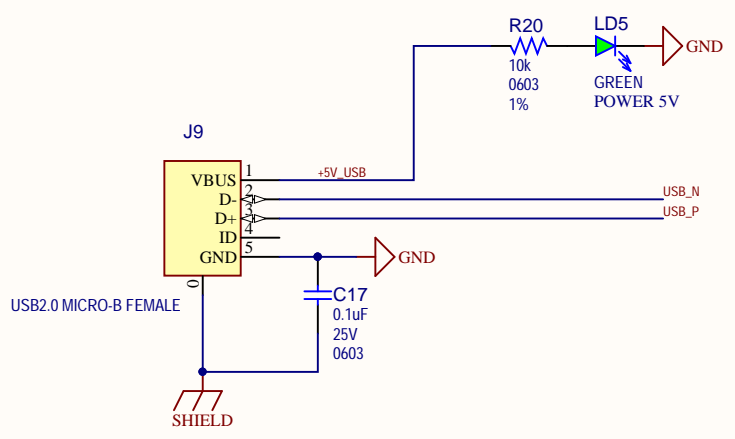
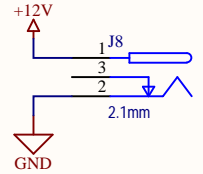
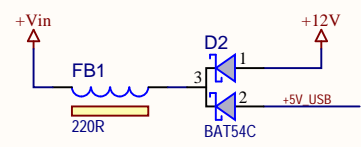
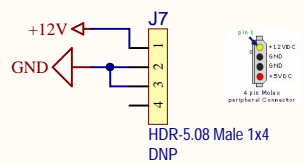
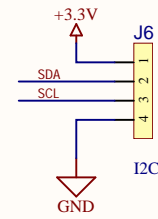
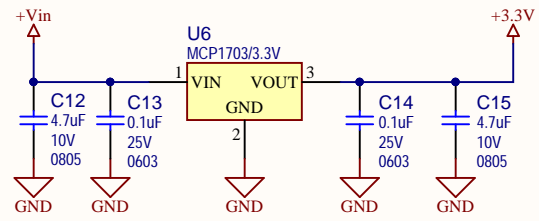
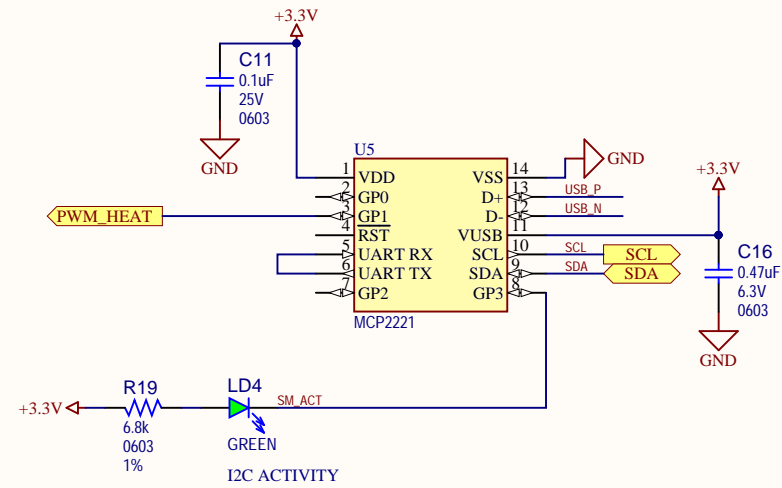

Drawn By: Bogdan Popescu		
Engineer: Bogdan Popescu		
PartNumber: ADM00879	Project Title EMC2305 & EMC1438 Fan Controller Demo	
Sheet Title Interface & Power		Designed with
Size B	Sch #03-10737	Date: 10/18/2018 11:33:25 AM
	Revision:3	Sheet 3 of 4
File: Interface & Power.SchDoc		

REV	ECO#	DESCRIPTION	DATE

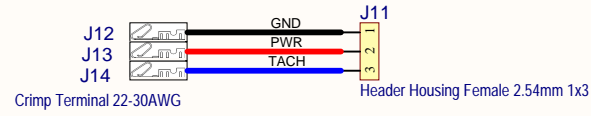
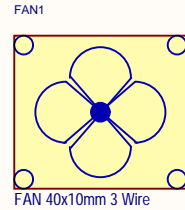

Example of remote diodes using NPN transistors

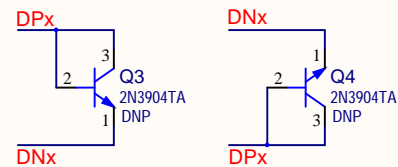

Drawn By: Bogdan Popescu			
Engineer: Bogdan Popescu			
PartNumber: ADM00879	Project Title EMC2305 & EMC1438 Fan Controller Demo		
Sheet Title Mechanical		Designed with 	
Size B	Sch #:03-10737	Date: 10/18/2018 11:33:26 AM	Altium.com
	Revision:3	Sheet 4 of 4	
File: Mechanical.SchDoc			