Driving LEDs with Constant Current and Sequential Linear LED Drivers

*Author: George Rasko, Surya Talari
Microchip Technology, Inc.*

INTRODUCTION

This document provides background and assistance to individuals who are considering the use of linear LED drivers (specifically, Sequential Linear LED Drivers and Constant Current LED Drivers from Microchip) for lighting applications. This also provides general technical help for other LED lighting applications.

BACKGROUND

Microchip makes a product line of Linear LED drivers intended for utility voltage LED lighting applications. To best understand these products, and to obtain optimized performance, certain topics need to be emphasized, even to those with a background in LEDs and lighting. This document clarifies particular characteristics of these driver chips and the applications that they support to encourage the highest probability of technical and marketing success.

LEDs are DC devices that are current-controlled. Since most power sources are AC sources and voltage-controlled, a translation between the power source and the LED load must occur to prevent catastrophic results. A simple example: Microchip's CL2 is a 20 mA current regulator. To use it in order to control a string of LEDs running off the utility mains, a diode bridge is first used to convert the incoming AC to a (pulsing) DC. Then, the CL2 is inserted in series with a suitable length string of LEDs to match rectified DC voltage. If the string is too long, the peak input voltage is less than the string voltage, and the LEDs will never light. If the string is too short, either 1) the power in CL2 will exceed its capability, or 2) the voltage drop across the CL2 will exceed its capability.

DOCUMENT CONVENTIONS TERMINOLOGY

The following terms and abbreviations are used in this document.

AC - Alternating Current. This is the typical power coming from the wall outlet. The voltage is a sine wave of a particular amplitude which alternates polarity at a specified frequency.

DC - Direct Current. Single-polarity power with an unchanging plus and minus.

OTP - Over Temperature Protection.

ALR - Active Line Regulation. Typically, an adjustment to the LED current done in order to keep the output light constant over changes in input voltage.

LED - Light Emitting Diode.

EMI - Electro Magnetic Interference. Unwanted emissions, either conducted or radiated.

NTC - Negative Temperature Coefficient. Refers to a thermistor (resistor whose resistance goes down as the temperature goes up).

MOV - Metal Oxide Varistor. A device which turns-on (goes to a low resistance state) at a particular voltage, used for transient overvoltage (lightning) protection.

OpAmp - An operational amplifier which drives a power FET into on/off/linear state to provide current control.

Sequential Linear LED Driver - A LED driver operating from a rectified AC voltage source, comprising multiple current regulators tied to various tap points along a long string of LEDs. High efficiency is achieved by shutting off upstream regulators when downstream regulators achieve regulation.

Tap - A junction between adjacent LEDs on a long string of series-connected LEDs.

Self-Commutation - A process of smooth transitions between current regulators (taps) based on using only the regulator currents themselves without sensing tap voltages or input voltages for control.

Strobing - A situation where light periodically visibly goes to zero, either at the input mains frequency, twice the mains frequency, or in an asynchronous manner.

Flicker - A measure of variation in the light output from a lamp, usually caused by the AC nature of the utility mains voltage. Flicker Index and Percent Flicker are the most widely used measures.

Efficacy - The term the lighting industry uses to refer to lumens per watt. The term efficiency is not used because efficiency is a dimensionless ratio of two numbers with the same units.

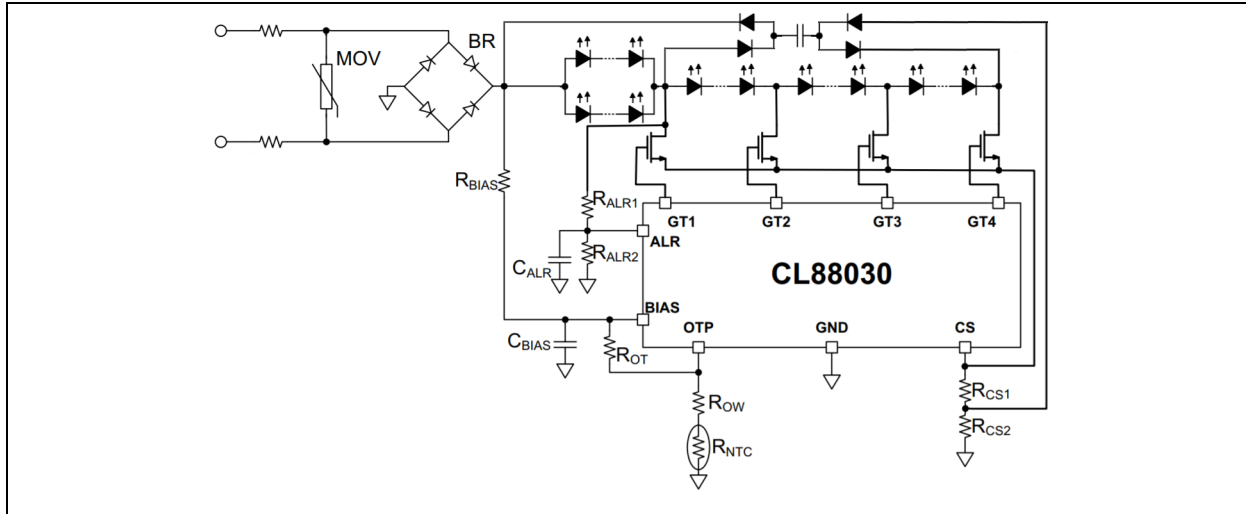

FIGURE 1: CL88030 Example (With Ripple Reduction).

STRING LENGTH

Proper use of Sequential Linear Drivers implies a significant constraint on LEDs and the electrical length of the LED string. A rule-of-thumb is: the DC voltage drop across the LED string should be roughly equal to the nominal RMS input voltage the application. The general description of the architecture is SERIES and LINEAR controller. There are two pieces in the series - the LEDs/load and the regulator. As such, the headroom, or voltage drop across the regulator, needs to be kept as low as possible to get the electrical efficiency as high as possible.

This constraint is one of the primary reasons that switching regulators are so popular. If you want to run a 30V string of LEDs off of the 230 VAC(RMS) coming out of a European/Asian wall outlet, this can be completed with a manageable and straightforward design process with a switching regulator. Switching waveforms create significant EMI, both conducted and radiated. This is why the switching regulator contains a non-trivial number of components not doing power conversion, but just keeping the electrical noise to a tolerable level.

Linear drivers are the complete opposite in this regard. To translate this constraint into numbers for a North American lamp: the 120 VAC(RMS) means a good starting point for the LED string voltage is 120 VDC. Assuming 3V per LED (a typical number for individual white LEDs), this means a string length of $120V/3V = 40$ LEDs. LED manufacturers make multi-chip packages for this reason: two chip (6V), four chip (12V), eight chip (24V) and others are available. If you look at the LED load for the CL88020 Evaluation Board, you will see 10 LED packages (24V each) wired in series/parallel for an electrical length of 6 packages, or about $6 \times 24V = 144V$ drop.

WHY IS THIS DONE?

Continuing this example, the peak nominal input voltage is $\sqrt{2} \times 120 \text{ VAC(RMS)} = 1.414 \times 120V = 169.7V$ (we will call this 170V). When the rectified input voltage is above 144V, the entire string is conducting. With four taps, the top three taps are off (nonconducting) and the bottom tap is 'on'. At this peak, there is $170V - 144V = 26V$ across the bottom FET. The current is regulated by both the effective series resistance of the LED string (not inconsequential) and/or the current regulation action of the bottom tap. Since the peak represents only a small part of the AC cycle, this is a manageable situation in terms of power dissipation in the bottom FET. The power in bottom in the bottom FET is maximum with a high line condition (maximum input voltage, typically +10% from nominal, $120V \times 1.1 = 132 \text{ V(RMS)}$, or 187 V(PEAK)). All of that 'extra' voltage is across the bottom FET. Conversely, the bottom FET/string is least active at low line condition (typically -10% from nominal, $120V \times 0.9 = 108 \text{ V(RMS)}$, or 153 V(PEAK)). With the bottom LEDs only 'on' for a small part of the AC cycle, there may be a visible shadow or uneven light from the lamp, even with a diffuser.

LED CURRENT/VOLTAGE, FET CURRENT/VOLTAGE

It can be difficult at first sight to understand how the LED currents and FET currents vary as the rectified input voltage goes through a half-cycle. This section will cover what is to be expected from a typical design. The example here will have no ALR control, no OTP protection, and no ripple reduction circuit. Basically, there is no stored energy. The explanation will start at the zero volts/zero crossing of the AC input.

AT ZERO

The CS voltage is zero. CS is below the reference voltages internal to the control chip, so all the FETs are on. There is no current flow when there is no applied voltage. As the rectified input voltage rises, it will eventually be greater than the drop across the top string. This is where/when current will start to flow. The voltage drop across the top string is less than the other, longer parts of the whole string, so the other LEDs remain off.

STRINGS

As the voltage rises further, the current in the 'top string' will be constant, with the FET1 drain voltage rising, until the FET1 drain voltage is high enough to turn on the 'second string'. This will cause the current in the TAP1 FET to decrease, while the current in the TAP2 FET will increase, and the second regulator will eventually take control, with current flowing in both the top and second strings. This is the idea of self-commutation (a reminder that the current set-point for the top string is less than that for the second string). This process continues for all the strings and it goes in reverse as the rectified input voltage falls after the peak.

Shown below in [Figure 2](#) is the LED string currents for a four-tap application. These are simulation results using the Mindi/Simplis/Simatrix model of the CL88020 available from the Microchip website. Features to note:

- The plateaus are the times when the current regulators are in the linear mode, holding the string to constant current levels.

- The top string operates initially at a low current, and then the current increases as the lower tap switch (larger number tap) turns on.

- The envelope of these currents is the input current - it is reasonably sinusoidal and in-phase with the input voltage, which means the input power factor is good (~0.96).

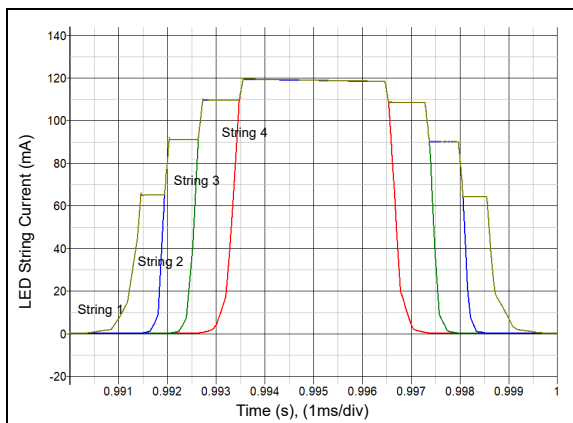

FIGURE 2: LED String Currents.

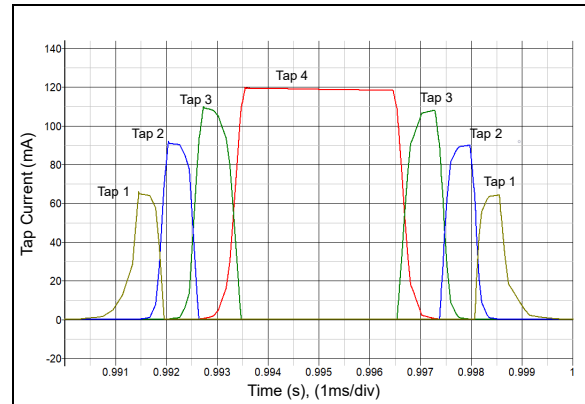

FIGURE 3: Tap Currents.

Note that the upstream taps all go to zero, and the bottom tap (Tap 4) stays on in the center of the input cycle. Next, we will look at the rectified input voltage, and the four tap voltages (as shown in [Figure 4](#)).

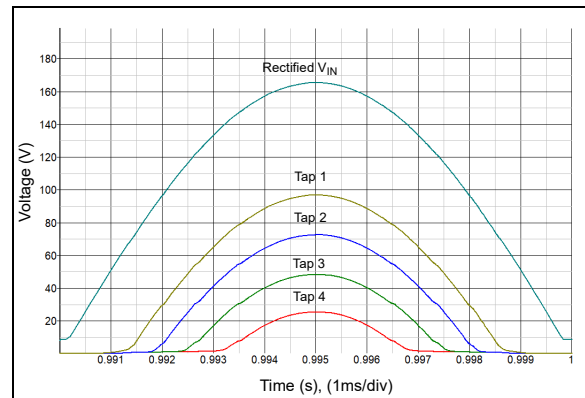

FIGURE 4: Tap Voltages.

Note that the rectified input voltage does not go to zero because at near-zero input voltage, the LED strings turn-off and the only load is a small trickle of chip operating current.

These plots in [Figure 2](#), [Figure 3](#) and [Figure 4](#) show that as the bottom string does not have another string (downstream) to off-load it, it behaves differently than the other strings. Once it comes on during the rising input voltage/current, it stays on until the input voltage/current falls below its threshold. FET1 has the highest voltage across it and lowest current through it, while FET4 has the lowest voltage and the highest current.

The above plots of voltage and current are the Stepping stones to POWER (volts x amps). There are two powers we are interested in: the power in the LEDs (which, except for the small amount of droop is proportional to the light output), and the power in the FETs (there is a comparatively small amount of power operating the chip, some power lost in the BIAS resistor, and sensing the current (CS). The input diode

bridge is a source of power losses as well. If we were discussing low-voltage lighting running off 12VAC, the diode bridge would be a more significant loss topic.

Since both voltage and current are changing in time, it can be difficult to understand what the various powers look like. Analyzing the real-time power in the LEDs has an additional value; it gives a way to measure the flicker of the output light.

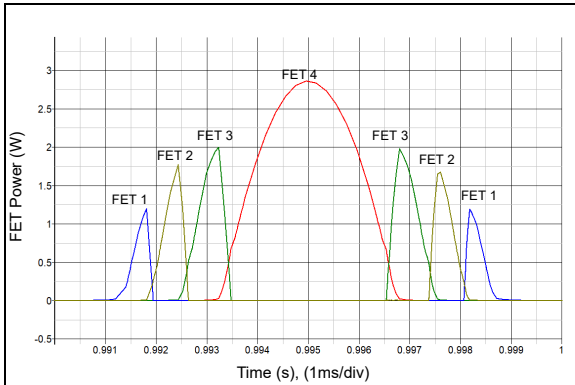

FIGURE 5: FET Power.

The top three FETs have modest power dissipation, while FET4 is the main source of losses. Next, we plot the LED power in Figure 6 (note that a bit of care needs to be exercised to properly account for the parallel connection of LEDs at various places in the string).

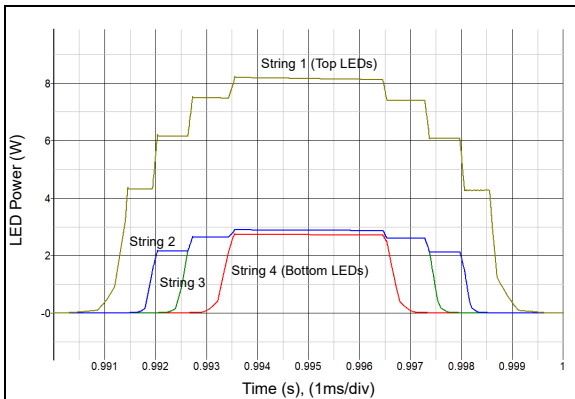

FIGURE 6: LED Power.

In Figure 6, we see the SEQUENTIAL nature of the architecture. The top LEDs are on the most and provide the most light, and the bottom LEDs provide the least. Since we are plotting the power, note that the evaluation board has six LEDs in the top, specifically to balance-out the LED power dissipation. The bottom LEDs have two in parallel.

The total light output looks like the sum of these four power curves. Figure 7 shows the total LED power.

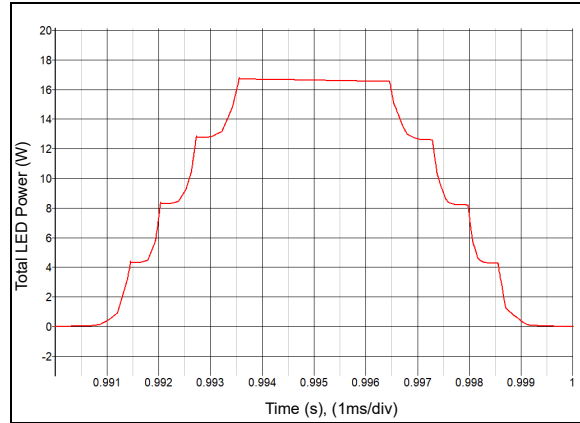

FIGURE 7: Total LED Power (Light Output).

Because there is no energy storage in this example driver design, the light goes to zero in the vicinity of the input voltage zero-crossings. This translates to 100% flicker, and ~0.36 flicker index.

RIPPLE/FLICKER REDUCTION

Adding four diodes and a capacitor around the chip/LED circuit can bring some improvement in the light quality. The CL88020 data sheet shows the recommended approach. Using the existing controlled currents means that the input power factor is reduced only slightly (additional energy will be taken during the 'on time' and stored for use during the 'off time' without having an active PFC circuit).

First, a short discussion about capacitors. The two capacitor constructions used the most are ceramic and electrolytic. Ceramic capacitors are robust (constructed of solid materials, with operating temperature having little effect), and have very low Equivalent Series Resistance (ESR), but do not provide as much capacitance per unit volume or as much capacitance per dollar as electrolytic capacitors. Electrolytic capacitors contain a liquid electrolyte (which can dry out or leak), are polarized (cannot be used for AC applications and will suffer rapid uncontrolled disassembly if driven in the wrong polarity), and need to have the environmental temperature given serious consideration for reliable use.

Another parameter needs to be mentioned: voltage coefficient. Typical ceramic capacitors have a significant voltage coefficient - the stated capacitance is at zero volts across the capacitor, and the capacitance can drop to 20% of this value at the rated capacitor voltage. Electrolytic capacitors have a low voltage coefficient - the stated capacitance is what you will get over a wide input voltage range. As an example, here is the voltage coefficient plot for the 100V ceramic capacitors on the CL88020 Evaluation Board.

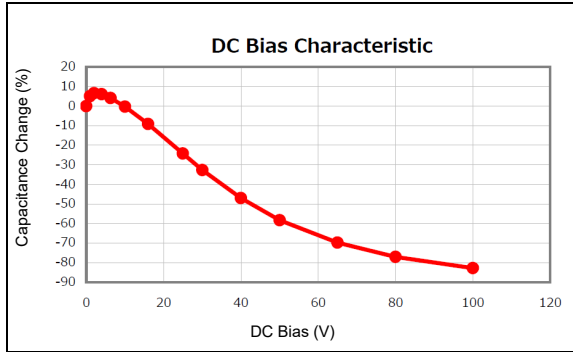

FIGURE 8: Ceramic Capacitor DC BIAS Correction.

The ripple capacitors have about 60 volts across them in the application, which means a 15 μF capacitor is effectively about 7 μF . For this reason, the two 15 μF capacitors in parallel on the board should be replaced by one 15 μF capacitor in simulation.

The basic effect of adding the diodes and ripple capacitor is to store energy in the capacitor in the center of the cycle, and discharge that energy into the top string during the valley of the input cycle. Here are the same four LED currents as before, but with the ripple diodes-capacitors added:

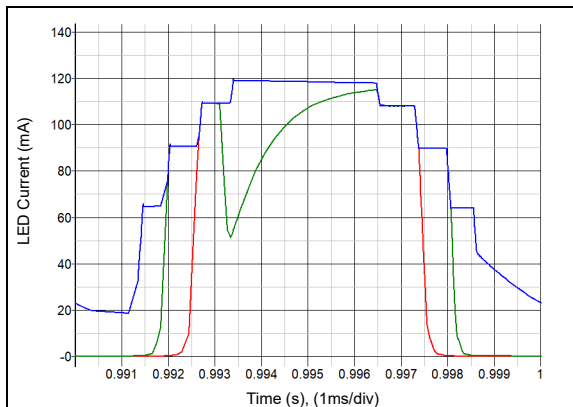

FIGURE 9: LED Currents with Ripple Capacitor.

The input current is only affected in a small way by this ripple reduction approach, so, the input power factor only drops by about 1%. With ripple reduction added, the complexity of the current flows and powers is such that it is hoped that the reader sees and understands that paper/spreadsheet analysis is only a starting point and simulation is the method to choose for more accurate results. With this modest ripple capacitor, the output light (total LED power) is shown in [Figure 10](#):

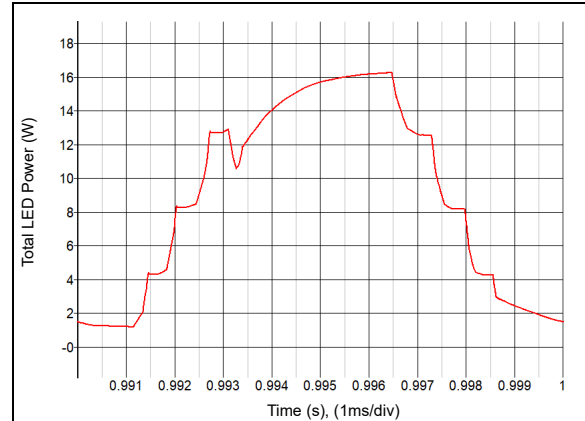

FIGURE 10: Light Output with Ripple Capacitor.

Because the capacitor fills with current through the top string, the capacitor voltage is essentially the rectified voltage minus the voltage of the top string. This limits the amount of discharge voltage available. The net of this is that the exponential valley can only be flattened with additional capacitance, and this increases the charge current, which flattens the top of the light output. Increasing the ripple capacitor from 15 μF to 150 μF gives as light output shown in [Figure 11](#):

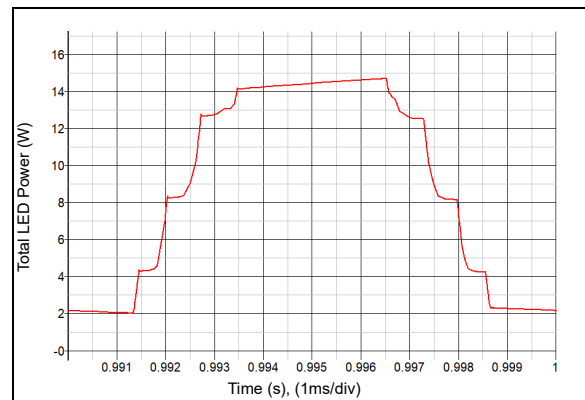

FIGURE 11: Light Output with Big Ripple Capacitor.

In summary, it doesn't pay to increase the ripple capacitor value beyond a modest exponential fill-in.

As a reminder, to get the simulation to behave correctly with such a large capacitance value, a 0.001 ohm resistor and 1 nH inductor were added in series with the capacitor.

Please note that when computing the IESNA flicker numbers, the vertical scale of the light output doesn't matter. You only need to know: 1) the vertical scale is linear, and, 2) where zero light output is.

ACTIVE LINE REGULATION (ALR)

One of the new features of the CL88020/30/31 (beyond the CL8800) is the addition of an ALR (Active Line Regulation) circuit. By adding two resistors and a capacitor to the ALR pin externally as shown in Figure 1, the application can make adjustments to the output power (light) so as to flatten the output light versus input voltage curve.

There are two approaches to implementing ALR. The approach used on the CL88020 Evaluation Board is to have the light output drop below nominal input voltage, and to have the knee of the curve at nominal, so there is only a small increase in light as the input voltage goes above nominal. The second approach (another typical customer request) is to have the light output be about the same when the input voltage is -10% and +10% from nominal. Shown in Figure 12 below is the LED power output from the same simulation model with the bottom ALR resistor set to 1 kΩ (no ALR function), 28 kΩ (knee at about 120VAC(RMS)) and at 37 kΩ (knee at about 108VAC(RMS)) (i.e. 120V-10%).

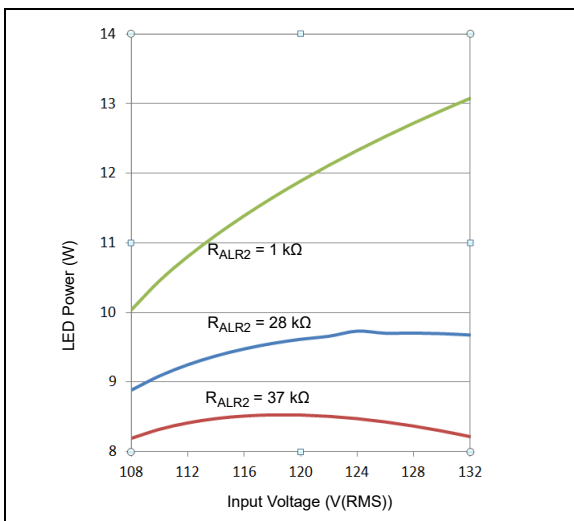

FIGURE 12: Output Regulation for Various ALR Implementations.

Note that because the input voltage to the ALR circuit is dependent on the voltage drop across the LEDs, this resistor value needs to be tuned for each application, based on the number of LEDs in the top string and the choice of particular LEDs.

HIGH LINE

One of the particulars of the Sequential Linear Driver architecture is that the bottom string and bottom FET are the items most affected by the input voltage going up. Figure 13 shows the simulation results for an application with the ALR knee set to -10% (flat), with the FET power plotted versus input voltage.

As you can see, FET4 is the one heavily affected by the input voltage increase, and its dissipation ends up dominating the total FET power dissipation.

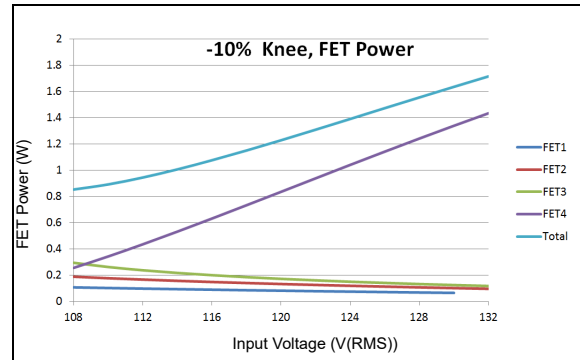

FIGURE 13: FET Power vs. Input Voltage.

DEVICE MODELS

When circuits and applications reach a certain level of complexity, analysis requires too many assumptions to give usable results, and simulation is the better approach. The modeling of the active devices is typically a painful part of putting together a simulation environment for an application. Some guidance to assist in this is provided below.

LED MODELS

LEDs are Light Emitting Diodes. Electrically, they are diodes. They conduct current in one direction. They have a higher voltage drop than a typical rectification diode because they have been optimized to put out light. In rough terms, red and green LEDs have about 2.0 volts drop, and blue/violet LEDs have about 3.0 volts drop (white LEDs are blue or violet LEDs which have a phosphor applied to make the other colors necessary to make the output light look white. This is similar to how fluorescent tubes put out ultraviolet light, and then use a phosphor coating on the inside of the glass tube to make white light).

The Spice simulator has a built-in diode model, which can be fed parameters to make a wide variety of diode characteristics. Large numbers of parameters and detailed models can very accurately simulate the electrical behavior. However, very accurate simulation is not the topic of discussion in this application note. To use a simple and good enough model which can move quickly onto working on the rest of the application circuit is what is needed. The Shockley diode model of the pn junction is the basis for what we want. [Note: Do not be confused by Shockley and Schottky. Shockley was an American scientist at Bell Labs, co-inventor of the transistor, and winner of the Nobel prize in physics,

Schottky was a German scientist at Siemens, and is the name of a type of diode that uses a metal-semiconductor junction to reduce voltage drop.].

The Shockley equation uses two parameters to describe the exponential V-I characteristic of diode. The two parameters are: 1) reverse saturation current, I_S , and, 2) a non-ideality factor, n . There is one constant from the analysis: V_T , the thermal voltage, equal to kT/q , where k is Boltzmann's constant, T is the absolute temperature, and q is the charge of the electron. At room temperature, $V_T = 0.02585V$. The Shockley diode equation is shown in Equation 1:

EQUATION 1: Diode Equation

$$I_D = I_S \left(e^{\frac{V_D}{nV_T}} - 1 \right)$$

The -1 makes the curve go through the origin (zero V_D means zero I_D). When the diode is at all active (not operating near zero volts or amps), the -1 can be ignored to simplify the equation because it is a very small number compared to the exponential term. The modeling problem is that this equation was used to describe a diode that was a good diode. LEDs are crappy diodes. When in the typically 'on' state, a LED's V-I curve is not a curve, is not exponential, and looks much like a resistor (straight-line) with a voltage offset. An example of a V-I curve for a LumiLEDs Luxeon 3535 LED is below.

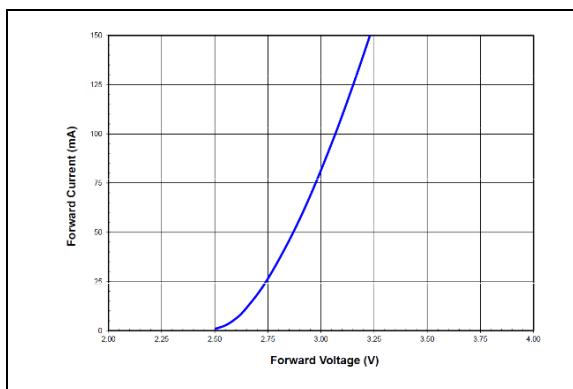

FIGURE 14: A Typical White LED V-I Curve.

The suggested model is: add a resistor to the typical diode model. This means there are three parameters we want to know. We do not need to worry about the actual reverse current in this application (the LED will never be driven that way), so it is just an adjustment factor to get the curve to go through the desired forward characteristic points. To solve the exponential, we break the problem in two pieces - look at the high current regime and get a resistor value, get this resistive effect out of the way, and solve for the other two parameters. Our curve needs three sample points (three vari-

ables), two of them near the tail. So, the process is: 1) add a resistor to the diode model, 2) determine the resistor value from the flat tail of the curve, 3) subtract the resistor effect to get a modified curve, 4) solve for the two remaining parameters. Example, from above. The three data points will be 150 mA at 3.20V, 125 mA at 3.15V, and 25 mA at 2.75V. An Excel spreadsheet is useful to do the calculations.

For the resistor, $R_S = dV/dI = (3.20-3.15)/(0.150-0.125) = 0.05/0.025 = 2\Omega$. Subtract the voltage drop across the resistor to give a new goal of 2.90V at 125 mA and 2.70V at 25 mA. The voltage difference is 0.2V, and the current ratio is 5. Divide two instances of the simplified Shockley equation (to eliminate I_S), use $\ln(5) = 1.609$, use $V_T = 0.02585$, and solve for $n = 4.807$, back substitute n into the simplified Shockley diode equation, and get $I_S = 9.15E-12$ A. Plotting the spreadsheet result gives (specifically including our three initial data points to check for agreement), and then plotting a Simplis/Simatrix/Mindi model below gives:

.model DLumi3535 D $I_S=9.15e-12$ $R_S=2$ $n=4.807$.

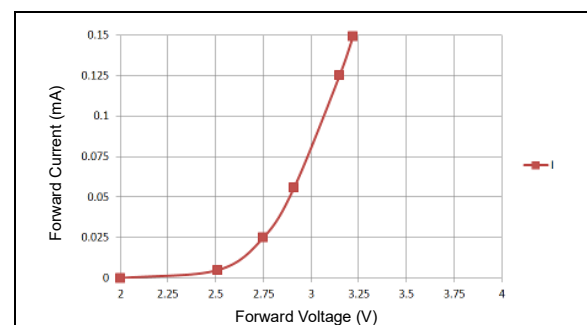

FIGURE 15: Spreadsheet Model V-I Curve.

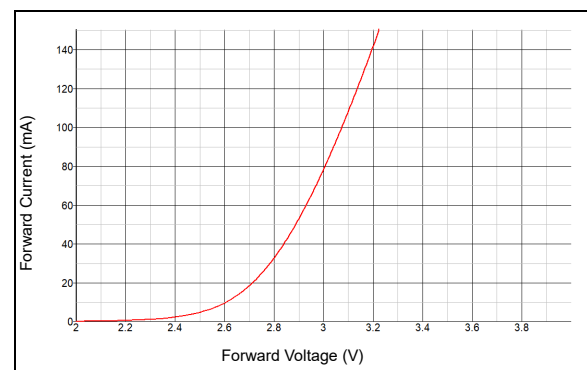

FIGURE 16: Simulation Model V-I Curve.

The model statement creates a local custom diode, using our three parameters. There is good agreement between the data sheet, the spreadsheet, and the Spice simulator. Note that this exact same procedure can be used to model multi-die LEDs. It may seem strange at first, but a resistor+exponential three parameter model can do a good job when the forward voltage is 22V, $n=20$ and the internal resistance is 11 Ω .

FET MODELS

Like the above LED exercise, the goal is to get a simple model and move on to the rest of the application. For low frequency applications, the only parameters of interest are the threshold voltage and the on-resistance. The good news is that the FET data sheet will usually give you the threshold voltage and the on-resistance. The standard Spice MOSFET model allows you to enter a threshold voltage. The tricky part is the on-resistance. The defining equations are complex, so a bit of trial and error is needed. The suggested approach is to make a simple Spice lab bench parametric FET analyzer.

Here is one approach: The example will be the VN2460 FET from Microchip (600V, 20Ω). The threshold voltage is 1.5-4.0V, and the main output curves look like:

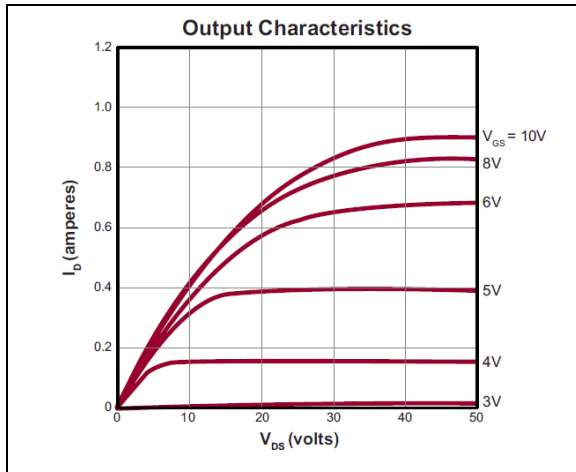

FIGURE 17: VN2460 Data Sheet Extract.

From the output curves, it looks like 3.0V would be a good choice for threshold voltage (there is no drain current below that gate voltage). The drain current has a 10V V_{GS} plateau of about 0.9A. The Spice model has both source and drain resistance. The source resistance combined with the threshold voltage will give this plateau. Be aware that having a source resistance will change the apparent threshold voltage, because the source-drain current through this source resistance makes a voltage that subtracts from the specified threshold. For a high voltage, high resistance FET like this, it is sometimes better to have an external resistor to set the on-resistance. Set up the simulation environment such that you are plotting the drain current versus voltage, with the gate voltage as a stepped parameter. For modern power FETs, a transconductance (K_P) of 1 is a good value. Having $R_S+R_D+R_{EXT}$ equal to your target value is a good place to start. The default value of LAMBDA (channel length modulation) in Spice is zero, so start there. First, run output plots with various values of R_S to get the top drain current plateau about right. R_{DSON} should be the slope of the curves at the origin (low V_{DS}). V_G curves will be pretty flat, and they will have a fairly sharp knee where they separate from

each other. Increase LAMBDA a small bit to put some slope on the characteristic curves and give them some curvature. The MOSFET simulation test schematic is shown in Figure 18:

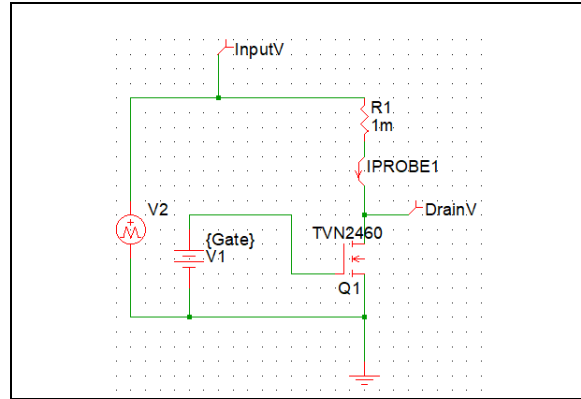

FIGURE 18: Simulation Test of FET.

FET (ENHANCEMENT MODE) MODEL

```
.model TVN2460 NMOS (VTO=3 RD=13 RS=7 KP=1 Lambda=1)
```

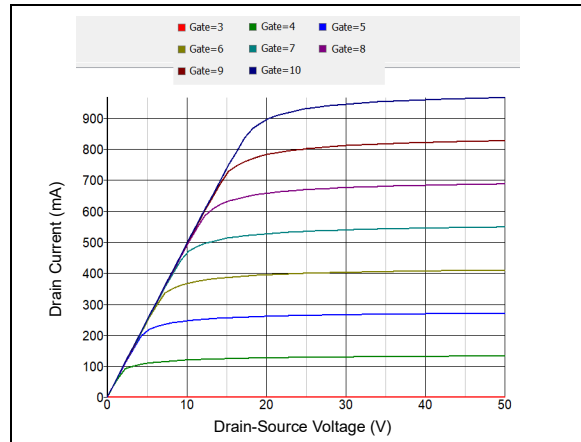

FIGURE 19: FET Simulation Results.

SIMPLIS COMMENT

This is in reference to a popular simulator from SIMPLIS Technologies. It is designed to use device models that are simpler than Spice (PWL - Piecewise Linear) with simulation times that are much shorter than with Spice or SIMetrix. (SIMetrix is a classic Spice simulator.) SIMetrix Technologies is headquartered in the UK, and is a separate company from SIMPLIS Technologies, located in the USA. These companies do have a joint marketing agreement for their two products. One caveat: the default MOSFET model has no linear region (on or off). When choosing a model extracted from the library of supplied devices (under Edit Part), be sure to select model level = 2 to get something that is not digital/binary in behavior.

A similar selection exists when using diodes from the library -- it is usually OK to select Model Level 0 - Conduction Only (which ignores capacitive effects), but it is very much recommended to always use 3 segments to get a transition region between on and off.

DEPLETION FETS

The typical MOSFET used in linear and switching power supplies is an enhancement-mode device. The n-channel version is most popular (because electron mobility is about three times higher than hole mobility) for cost-performance reasons. There is one FET device that is seen less often that should be noted because it is a very useful way to make a constant current regulator. An n-channel depletion-mode FET is normally-on device has a negative gate voltage to turn it off. By connecting a resistor to the source, and connecting the gate to the other side of the resistor, you have made a two-terminal device which will conduct just enough current to make the voltage drop across the resistor equal to the threshold voltage. As an example of Microchip's constant current regulator chips, the CL220 has a minimum voltage drop of 5V, and regulates to 20 mA. Setting the model threshold voltage to -5V, an initial guess for the resistor value is $5V/0.02A = 250\Omega$. Using Spice MOSFET parameters similar to those used earlier (the resistances should have minimal effect here because the current is so low), and running a plot of current versus voltage with a bit of experimenting, a 238 Ω resistor gives the response in Figure 21 from the following schematic in Figure 20:

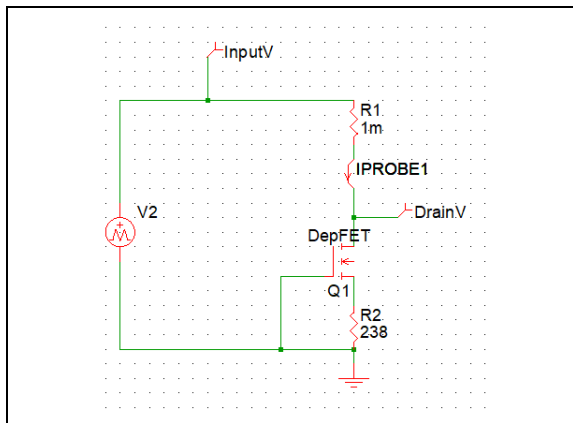

FIGURE 20: Depletion FET Test Circuit.

DEPLETION FET MODEL

```
.model DepFET NMOS (VTO=-5 RD=2 RS=2 KP=1)
```

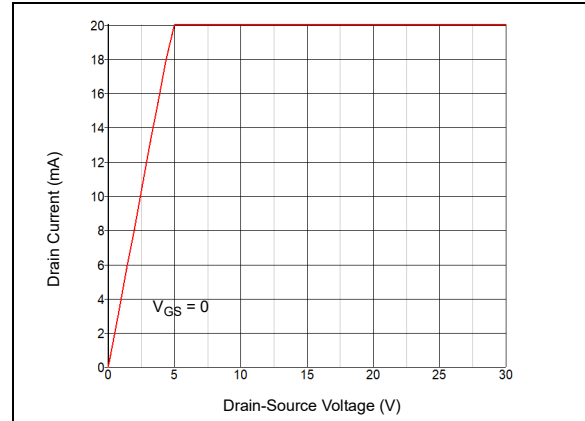

FIGURE 21: Depletion FET Constant Current Test Result.

It is obvious to find a striking similarity between this result and the performance of the Microchip CL2 current regulator chip.

One other comment: as a single-level controller, when used as an LED driver like the above schematic (change to an AC utility-like input source, add a diode bridge, add LEDs in series), the power factor will be modest and the efficiency will be low unless the LED string voltage is close to the rectified voltage. The simplicity of the implementation needs to be weighed against the need for these performance metrics.

SEQUENTIAL LINEAR LED DRIVER EXAMPLES

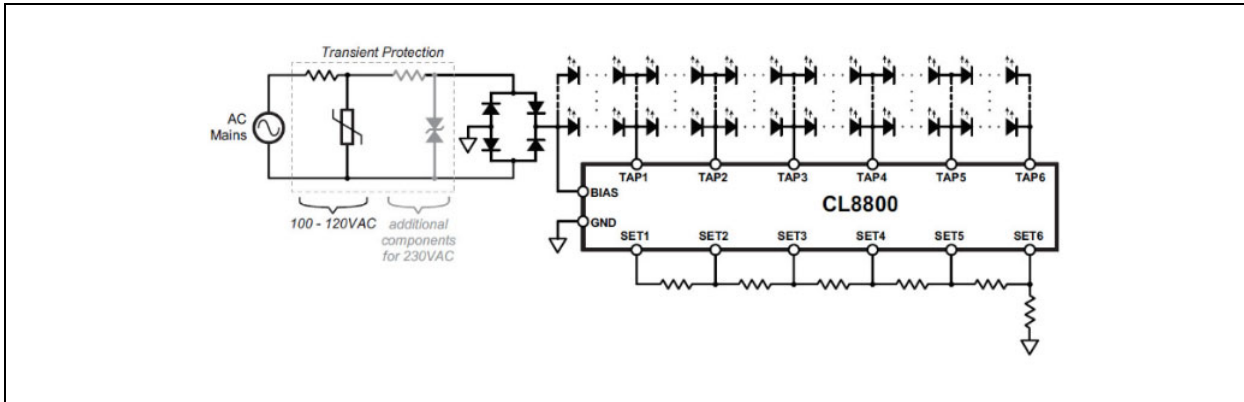

FIGURE 22: CL8800 Example.

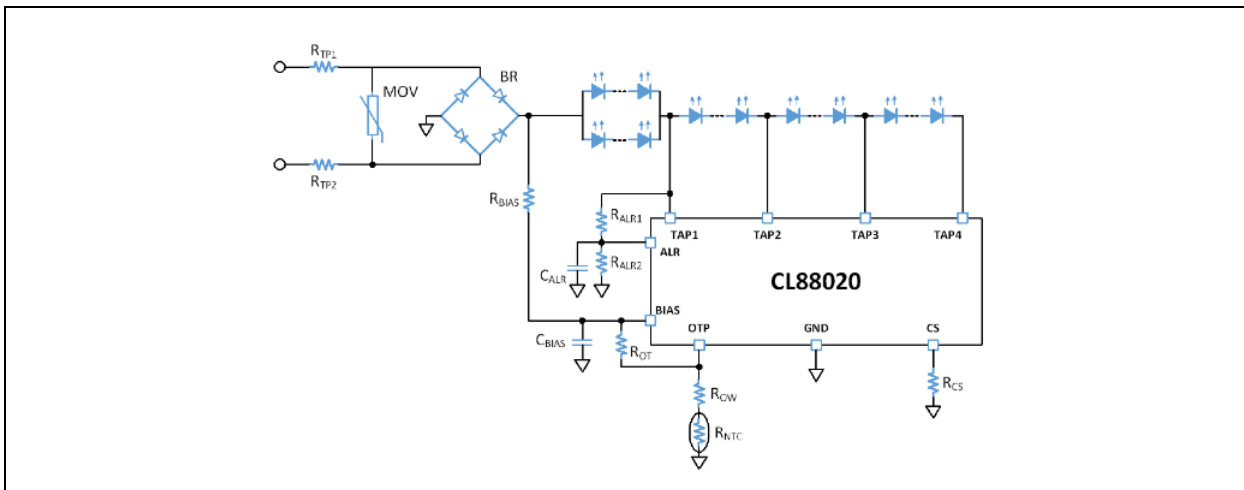

FIGURE 23: CL88020 Example.

Note that there is no need for magnetics, either for power conversion or for EMI suppression.

APPENDIX A: ANALYSIS OF SINGLE LEVEL, CONSTANT CURRENT DRIVE OF AN LED STRING

Analysis of a single-level constant current linear LED driver driven by a rectified AC source can be done with reasonable assumptions and a bit of math to give good results.

EFFICIENCY

LED driver efficiency is the power in the LEDs divided by the input power supplied to the LED driver. While a closed-form analytic solution is not readily available, a procedure with only a couple of steps will give usable results. The assumptions are: 1) there is no energy storage (no capacitors of consequence), 2) the breakover voltage for the current controller is zero, and

3) we ignore rectification losses. The current (both current from the source and through the LEDs) will be a rectangle (constant current) with an on-time centered around the input voltage peak. This on-time will have a particular duty cycle. The current will begin conducting when the input voltage reaches the LED string voltage. It will be useful to have the conduction angle for this to occur, which is obtained in [Equation 2](#):

EQUATION 2:

$$\theta = \sin^{-1}\left(\frac{V_D}{V_{PEAK}}\right)$$

where V_D is the voltage drop across the LED string, and V_{PEAK} is the peak input voltage. If we work in units of degrees, the duty cycle of the current is calculated in [Equation 3](#):

EQUATION 3:

$$D = \frac{90 - \theta}{90}$$

The average and RMS values of a square wave of amplitude A and duty cycle D are computed in [Equation 4](#):

EQUATION 4:

$$A_{AVG} = A \times D \quad A_{RMS} = A \times \sqrt{D}$$

Let I be the constant current, and the single-level constant current linear LED driver efficiency can be defined as in [Equation 5](#):

EQUATION 5:

$$Eff = \frac{LED\text{Power}}{Real\text{InputPower}} = \frac{V_D \times I_D \times D}{V_{RMS} \times I_{RMS} \times PF}$$

$$Eff = \frac{V_D \times I \times D}{V_{RMS} \times I \times \sqrt{D} \times PF} = \frac{V_D \times \sqrt{D}}{V_{RMS} \times PF}$$

Note that the efficiency is independent of the value of the regulated constant current, and that the denominator is Real Input Power, not Apparent Power.

POWER FACTOR

The power factor is defined in [Equation 6](#):

EQUATION 6:

$$PF = \frac{Real\text{InputPower}}{Apparent\text{InputPower}}$$

Apparent Input Power is defined in [Equation 7](#):

EQUATION 7:

$$Apparent\text{InputPower} = V_{RMS} \times I_{RMS}$$

The real input power is the average of the instantaneous input power and is calculated by integration in [Equation 8](#):

EQUATION 8:

$$P_{AVG} = \frac{1}{T} \int_0^T V(t) \times I(t) dt$$

T is the period of the input voltage. I(t) is a constant value when 'on', and zero elsewhere. Because of symmetry, we only need to look at a half of a cycle. Because the power will be zero when the current is zero, we only have to integrate when the current is 'on'. The input voltage is a sine wave, and the integration limits are centered around the voltage peak at t = T/4. Combining these observations, the average power equation is modified as in [Equation 9](#):

EQUATION 9:

$$P_{AVG} = \frac{2 \times V_{PEAK} \times I}{T} \int_{\theta T/2\pi}^{T/2} \sin \frac{2 \times \pi \times t}{T} dt$$

We can simplify further by using symmetry again - the average power will be twice the average from beginning of conduction to the peak of the input voltage. This makes evaluating the definite integral easier, because the integral of sine is cosine, and cos(π/2) = 0. Also, our conduction angle from previous is useful. Using these insights, the average power equation is further modified as in [Equation 10](#):

EQUATION 10:

$$P_{AVG} = \frac{4 \times V_{PEAK} \times I}{T} \int_{\theta T/2\pi}^{T/4} \sin \frac{2 \times \pi \times t}{T} dt$$

After evaluating, the average power calculation for the single-level constant current linear LED driver is simplified in [Equation 11](#):

EQUATION 11:

$$P_{AVG} = \frac{2 \times V_{PEAK} \times I \times \cos \theta}{\pi}$$

Using this result in the equation for power factor as shown in [Equation 12](#):

EQUATION 12:

$$PF = \frac{\frac{2 \times V_{PEAK} \times I \times \cos \theta}{\pi}}{V_{RMS} \times I_{RMS}} = \frac{2 \times V_{PEAK} \times I \times \cos \theta}{\pi \times \frac{V_{PEAK}}{\sqrt{2}} \times I \times \sqrt{D}}$$

and finally, the computation of power factor for the single-level constant current linear LED driver is derived in [Equation 13](#):

EQUATION 13:

$$PF = \frac{2 \times \sqrt{2} \cos \theta}{\pi \times \sqrt{D}}$$

Substituting [Equation 13](#) into the efficiency in [Equation 5](#), the resulting efficiency calculation for single-level constant current linear LED driver is derived in [Equation 14](#):

EQUATION 14:

$$Eff = \frac{V_D \times \sqrt{D}}{V_{RMS} \times \frac{2 \times \sqrt{2} \cos \theta}{\pi \times \sqrt{D}}} = \frac{\pi \times V_D \times D}{V_{RMS} \times 2 \times \sqrt{2} \cos \theta}$$

Note that the power factor (like the efficiency) is independent of the value of the regulated constant current. The interrelationship of duty cycle, conduction angle, and trigonometric functions makes the plot of both of these results non-obvious at first glance. Since both efficiency and power factor are quantities between 0 and 1, it is useful to evaluate them versus LED string voltage V_D and plot both of the results on the same graph. To add credibility and verify the assumptions and analysis, a simulation was run as well. The input voltage is 120VAC(RMS) (169.7V peak).

The simulation is run at 50 Hz to simplify finding integer numbers of cycles to compute the rms and average waveform values. In simulation, the LEDs are replaced by a diode blocking a voltage source. There is good agreement between analysis and simulation. The simulation results of power factor and efficiency versus LED string voltage is plotted in Figure 25. Note that the efficiency goes up with string length, power factor has a maximum, and that the maximums occur at different V_D voltages. The test schematic is shown in Figure 24:

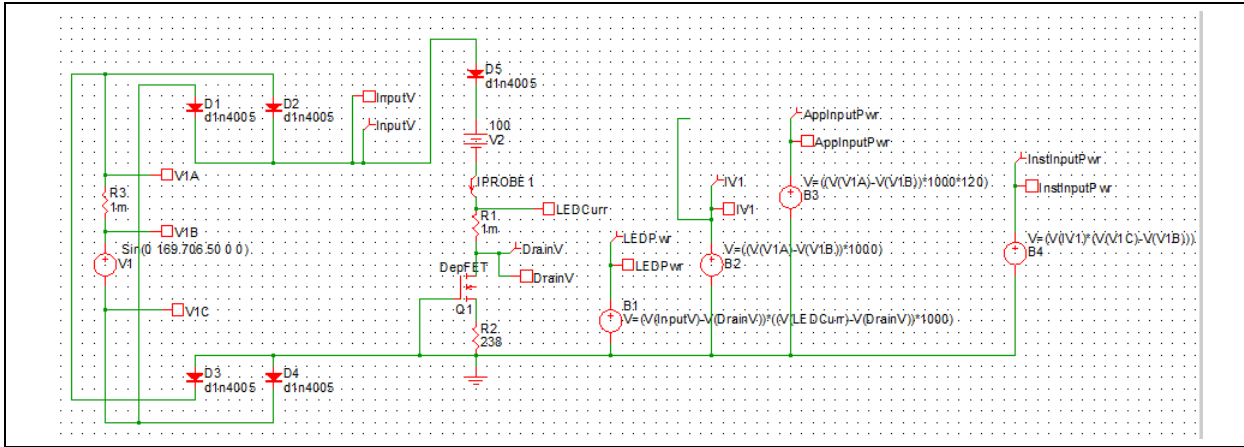

FIGURE 24: Power Factor/Efficiency Test Schematic.

A simulation comment: to compute PF, simulate an integer number of input cycles and then 1) generate a graph of input current, 2) take the rms of this, 3) generate a graph of instantaneous input power, 4) take the mean of this, and 5) use these two scalar values with the known rms input voltage to compute PF.

APPENDIX B: AN ALTERNATE MULTI-TAP SEQUENTIAL LINEAR LED DRIVER

The Sequential Linear examples using the CL8800 and CL88020/30/21 are what might be called parallel control topology. All the FETs connect to a common-source point, which is the point where all current sensing takes place. This approach works well for integrated IC solutions, because the current sensing is ground-referenced, and at a single place. It is also efficient, since there is only one current sense resistor burning power. There is a less obvious approach as well, that might be called the serial control topology.

This is a series of single channel current sources, each with their own current sensing. Because we used the depletion FET as a current controller before, we can use it again. Here, we will use the depletion FET as-is and won't have the threshold voltage artificially mimic an integrated current controller chip. But, we will idealize the situation by making all the FETs have a fixed, known gate threshold voltage (real FETs have wide threshold voltage variations). The depletion FET used here, the DN2540 (400V, 25Ω, 1.5V threshold), has a detailed simulation model available on the Microchip website. The schematic for the proposed alternate four-tap sequential linear LED driver (120 VAC(RMS)/ 50 Hz input) is shown in Figure 26:

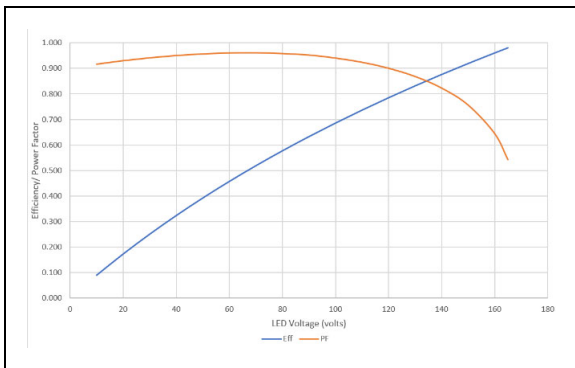

FIGURE 25: Power Factor/Efficiency vs. LED String Voltage.

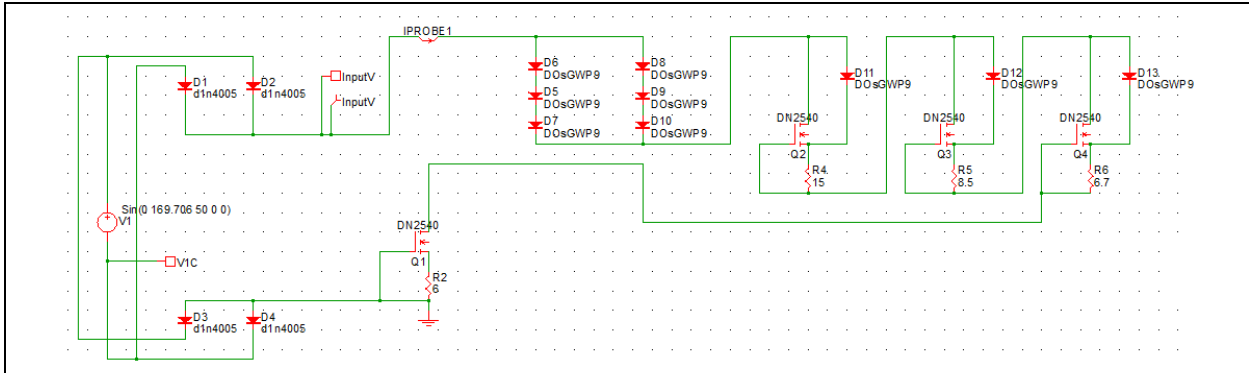

FIGURE 26: Test Schematic.

The LEDs are multichip versions, about 25V each. The four current steps are 66 mA, 98 mA, 115 mA, and 124 mA (set by corresponding sense resistors). Note that because of the way the LEDs are wired to the FETs, Q2/Q3/Q4 see a maximum of ~30V across them (don't need high voltage FETs). Q1 is the FET that has the most voltage and power (all the FETs and sense resistors see the full current). The rectified input current has the familiar sequential linear staircase shape as displayed in Figure 27:

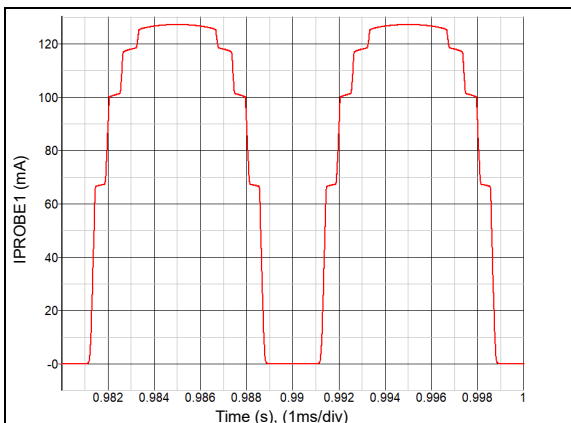

FIGURE 27: Input Current, Parallel Control Topology 4-Tap Sequential Linear LED Driver.

APPENDIX C: REGULATORY, CONDUCTED EMISSIONS, FLICKER

LIGHTING DEVELOPMENT HISTORY AND COMMENTS

The ideal light bulb takes energy/power from the utility source in a sinusoidal fashion (100% power factor like a resistor load) and puts out DC light, or continuous light with no variation in time related to the AC sine wave input.

The incandescent lamp behaved fairly well in terms of compatibility. It looked like a resistor to the utility and had a lot of thermal inertia to make the light output reasonably smooth. But it proved to be inefficient. The fluorescent lamp [1] and the compact fluorescent lamp were much more efficient, yet had challenges. The color of the light was poor. The flicker was 100Hz/120Hz. There was a hum from fluorescent magnetic ballasts and a bad power factor. There was mercury vapor inside the fluorescent glass tube.

LEDs came along, and the blue LED plus phosphor made for the next revolution in lighting. The government was very interested in supporting efficient lighting. They felt that without intervention, the LEDs lamps would be rejected by the public due to poor quality of light and poor electrical behavior.

[1] Thomas Edison invented a fluorescent lamp running on X-rays. Edison abandoned his research following the death of his assistant, Clarence Madison Dally, the first American to die from the effects of radiation. American electrical engineer Peter Cooper Hewitt invented a more practical design. German inventor Edmund Germer later made improvements to PCH's design to make it commercially viable.

EUROPE/HARMONICS

The EU implemented EN61000-3-2 to control power line harmonics. The regulations cover the low frequency current harmonics (the first 40 harmonics of the power line frequency) from various loads. There is a

AN3444

specific section on lighting (Class C load), because it is such a significant percentage of the utility load. The latest version of the regulation at this writing is 2018.

As a short summary, which should NOT be considered to be in any way exhaustive, see below. Nomenclature here is [harmonic number]=level:

- lamps below 5 watts are not regulated
- harmonics less than 0.6% of the input current, or 5 mA, are ignored
- lamps greater than 25 watts are regulated by a table of permissible percentages of the fundamental. 2=2%, 3=30xPF, 5=10%, 7=7%, 9=5%, all other odds=3%.
- lamps from 5 to 25 watts are regulated on an allowed current per rated watts. Units are mA per watt: 3=3.4, 5=1.9, 7=1.0, 9=0.5, 11=0.35, odds 13 to 39=3.85/H (H is the harmonic number)

The measurement requires a calibrated spectrum analyzer and diligence. Like any regulatory requirement, compliance is a complicated endeavor.

THD

Total Harmonic Distortion is a single number measure of how much a periodic wave deviates from a sinusoid. It is most used in audio, but is referenced in other contexts. Specifically, the regulations above for 5-25 watts have an alternative means of compliance that involves THD and percentages of the fundamental if the THD is less than 70%.

The calculation of Total Harmonic Distortion is given in [Equation 15](#).

EQUATION 15:

$$THD_F = \frac{\sqrt{V_2^2 + V_3^2 + V_4^2 + \dots}}{V_1}$$

The THD of a 50% duty cycle square wave, and the THD of a square wave of duty cycle μ are calculated in [Equation 16](#):

EQUATION 16:

$$THD_F(0.5) = \sqrt{\frac{\pi^2}{8}} - 1 \approx 0.483 = 48.3\%$$

$$THD_F(\mu) = \sqrt{\frac{\mu(1-\mu)\pi^2}{2\sin^2(\pi\mu)}} - 1, \quad 0 < \mu < 1$$

FOURIER TRANSFORMS/FFT

The way to get to these harmonics is through Fourier Transforms of the input current. The mathematic technique typically used on measured data is the Fast

Fourier Transform. Some Spice simulators can do post-processing of the time series data to give harmonics, THD, and FFT results.

Here is a simulation example using the free ngspice Spice simulator (old school - no schematics, text netlist input).

```
* file name rcrcTran.cir
R1 int in 10k
V1 in 0 PULSE (-0.5 0.5 0 1n 1n 10m 20m 0)
R2 out int 1k
C1 int 0 1u
C2 out 0 100n
.control
set nfreqs=41
tran 5u 60m
plot in, out
fourier 50 in
.endc
.end
```

Fourier analysis for input current:

No. Harmonics: 41, THD: 47.1098%, Gridsize: 200, Interpolation Degree: 1

Harm#	Freq	Magnitude	Phase	Normalized Magnitude	Normalized Phase
0	0	-3.8744e-12	0	0	0
1	50	0.63663	0.812244	1	0
2	100	7.74883e-12	-90	1.21716e-11	-90.812
3	150	0.212241	2.43703	0.333382	1.62479
4	200	7.74901e-12	-90	1.21719e-11	-90.813
5	250	0.127382	4.06271	0.200088	3.25046
6	300	7.74885e-12	-89.999	1.21716e-11	-90.811
7	350	0.0910273	5.68987	0.142983	4.87763
8	400	7.74886e-12	-89.999	1.21717e-11	-90.811
9	450	0.0708409	7.31911	0.111275	6.50686
10	500	7.74878e-12	-89.999	1.21715e-11	-90.811
11	550	0.0580038	8.951	0.0911105	8.13876
12	600	7.74886e-12	-90	1.21717e-11	-90.812
13	650	0.0491243	10.5861	0.0771628	9.7739
14	700	7.74923e-12	-90	1.21722e-11	-90.812
15	750	0.0426195	12.2251	0.0669453	11.4129
16	800	7.74866e-12	-89.999	1.21714e-11	-90.812
17	850	0.0376514	13.8684	0.0591417	13.0562
18	900	7.74872e-12	-90	1.21714e-11	-90.812
19	950	0.0337351	15.5167	0.05299	14.7045
20	1000	7.74903e-12	-89.997	1.21719e-11	-90.809
21	1050	0.0305701	17.1705	0.0480185	16.3583
22	1100	7.7489e-12	-89.999	1.21717e-11	-90.812
23	1150	0.0279607	18.8303	0.0439198	18.0181
24	1200	7.74896e-12	-89.998	1.21718e-11	-90.81
25	1250	0.0257738	20.4967	0.0404847	19.6845

26	1300	7.7488e-12	-90.001	1.21716e-11	-90.813
27	1350	0.0239157	22.1702	0.037566	21.3579
28	1400	7.74869e-12	-90.001	1.21714e-11	-90.813
29	1450	0.0223186	23.8512	0.0350573	23.039
30	1500	7.74914e-12	-90.002	1.21721e-11	-90.815
31	1550	0.0209322	25.5403	0.0328795	24.728
32	1600	7.74966e-12	-89.998	1.21729e-11	-90.811
33	1650	0.0197184	27.2378	0.0309729	26.4256
34	1700	7.74995e-12	-89.995	1.21734e-11	-90.807
35	1750	0.0186478	28.9444	0.0292914	28.1321
36	1800	7.74887e-12	-90.002	1.21717e-11	-90.814
37	1850	0.0176976	30.6602	0.0277987	29.848
38	1900	7.74928e-12	-89.996	1.21723e-11	-90.808
39	1950	0.0168493	32.3859	0.0264663	31.5736
40	2000	7.74902e-12	-90.003	1.21719e-11	-90.815

This is a 50 Hz square wave, 50% duty cycle, 1V pk-pk, centered on the x-axis (no DC). The computed THD (47.1%) is close to the theoretical value (48.3%). Note that Spice typically defaults to 10 harmonics. This simulator gives the DC value as the zeroth harmonic, so we ask for 41 harmonics to see everything the EU would want. The netlist has an RC filter for the output, so a plot of the input (in red) and output (in green) is illustrated in [Figure 28](#):

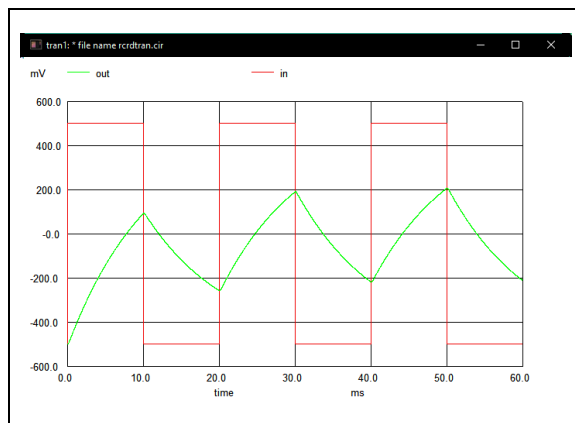

FIGURE 28: RC Example.

In the Simetrix/Mindi waveform pane, if you apply the Distortion measurement to a waveform, you will get its THD. But it only uses the first ten harmonics. The measured THD value is not accurate enough.

Plus, the regulatory institutes in Europe want to look at the first 40 harmonics. The solution for SIMetrix is to run a script on the waveform data after running a simulation. Usually, the only thing needed is a waveform signal that is the input current.

The logistical details to get the harmonics and THD number are:

- Use a script file called `four40.sxscr`

It computes the first forty harmonics of a specified variable at specified frequency spacing using a Fourier transform, and computes the THD from those harmonics from a sum of squares.

- Have `four40` in the same directory with the simulation file.
- Run the simulation.
- If the simulation runs at 50Hz input current, save the last 20 ms of the simulation, and, here, `InstInCurr` is a net name for the instantaneous input current (we usually compute it with a voltage source running off a sense resistor). Go to the command line (upper left corner of the simulation window. The command line might be hard to see if the command shell is too narrow.) and type in:

```
four40 50 InstInCurr
```

- You should see in the command shell window a listing of harmonics, and at the end, the THD:

The `four40.sxscr` script file:

```
** .FOUR equivalent
```

Arguments frequency var

```
Let analysisVec = ':' & SystemValue ('ANALYSIS_VECTOR')
if !ExistVec(analysisVec) then
    Echo "No simulation results available"
    exit script
endif

if Vec(analysisVec)<>'Transient' then
    Echo "Need transient analysis results for Fourier operation"
    exit script
endif

if RefName(var)<>'Time' then
    Echo "Cannot perform fourier transform on specified signal"
    exit script
endif

Let endTime = (Ref(var))[Length(var)-1]
Let startTime = endTime-1/frequency

if startTime<0 then
    Echo "Analysis time must be greater than 1/frequency"
    exit script
endif
```

AN3444

```

Let trunc = Truncate(var, startTime)
Let numHarmonics=64
Let fft = FFT(Interp(trunc, numHarmonics*2),
'none')

Let Magnitude = mag(fft)
Let Phase = phase(fft)
Let Magnitude[0] = Mean1(trunc)
show /clipboard Phase, Magnitude
show Phase, Magnitude
Let distortionSquared=0

for idx=2 to numHarmonics-1
    Let distortionSquared = distortionSquared
+ Magnitude[idx]*Magnitude[idx]
next idx

Let thd = (sqrt(distortionSquared))/Magni-
tude[1]
Echo {'THD=' & formatnumber(thd, 4, '%')}
---
```

A typical set of Simetrix results using four40:

Frequency	Magnitude	Phase
0	5.78E-05	0
50	0.530412879	89.79290977
100	5.15E-05	178.6743466
150	0.038925079	266.378771
200	1.26E-05	181.9905645
250	0.071475706	270.1116364
300	2.99E-06	350.9043707
350	0.043269749	270.4510911
400	2.25E-06	352.8027709
450	0.007435554	269.3979308
500	1.95E-06	185.3086141
550	0.008633722	88.22268936
600	1.24E-05	1.158355863
650	0.017836753	89.66272354
700	6.63E-06	175.0486724
750	0.013921653	91.06366451
800	1.30E-06	19.49210261
850	0.00041943	-80.91995575
900	1.08E-06	-187.4177432
950	0.002293767	-91.99741197
1000	3.31E-06	-172.6935012
1050	0.00712891	-90.39493935
1100	1.13E-06	-135.8569452
1150	0.008309458	-91.17817031
1200	3.03E-06	-165.8996614
1250	0.006773207	-86.76711783
1300	1.61E-05	0.291434598

Frequency	Magnitude	Phase
1350	0.00309844	83.9154791
1400	6.24E-06	171.6259714
1450	0.01434532	91.92455616
1500	8.47E-06	174.2819566
1550	0.008124665	91.9804656
1600	1.89E-06	169.777038
1650	0.002705528	272.3024297
1700	6.42E-06	357.4056732
1750	0.012381781	272.2227185
1800	8.91E-06	355.9115427
1850	0.007439136	268.8295442
1900	1.26E-05	184.1992345
1950	0.004802354	93.17385844
2000	3.45E-06	-10.87061538
2050	0.005134096	88.1718033
2100	6.84E-07	154.1458849
2150	0.003213806	90.05782531
2200	1.61E-06	40.64875797
2250	0.0006637	87.93022101
2300	1.25E-06	113.6116052
2350	0.002364212	266.0668548
2400	2.80E-06	172.5970087
2450	0.00324557	273.2717553
2500	7.71E-06	355.9182183
2550	0.000424492	457.6580875
2600	9.18E-06	547.8490547
2650	0.002343671	453.8441819
2700	6.05E-06	348.8229517
2750	0.002261029	278.1642464
2800	2.84E-06	358.2159365
2850	0.000950847	270.1602317
2900	3.88E-06	166.1350354
2950	0.001647147	97.99427676
3000	5.98E-06	168.0411227
3050	0.00174037	101.7485072
3100	3.93E-06	170.1626874
3150	0.001496846	74.16174676

THD=18.76%

Be careful about the definition of amplitude in Fourier analysis. The first example above has a total excursion of 1. The measured fundamental is 0.636. Theoretically, it should be $2/\pi = 0.6366$. Wikipedia, under square wave, calls going from -1 to +1 an amplitude of 1" and says the first harmonic should be $4/\pi$. THD isn't affected by this because it is a normalized amplitude. Also note that Fourier analysis deals with the peak amplitudes of sine waves, while the regulatory standard requirements deal with both percentages of the fundamental signal (unaffected by this) and RMS currents (affected).

FLICKER

There are two longstanding definitions of flicker: 1) Flicker Index, and 2) Percent Flicker. These definitions do not consider how fast the human eye responds. The new IEEE methodology does address this. Percent Flicker is simplest and uses only the minimum and maximum light amplitude. Flicker Index involves finding the average light, the amount of light above this, and completing a computation. See below in [Figure 29](#):

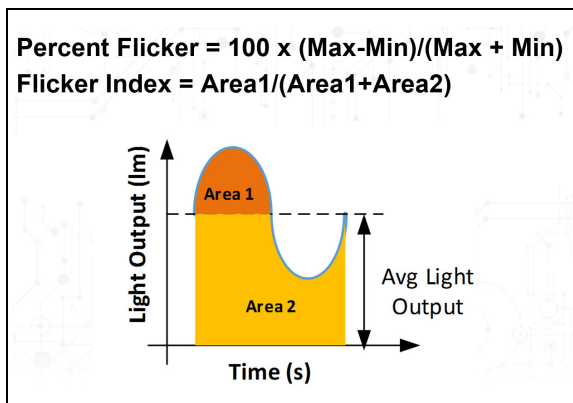

FIGURE 29: *Flicker Definition.*

Note that neither definition requires measuring absolute light levels. All you need is a linear sensor, a sensor whose bandwidth is a couple times greater than the power line frequency, and zero light level data.

According to a Department Of Energy study, a standard 60W A19 [2] incandescent lamp has a Percent Flicker of 6.6% and a Flicker Index of 0.02. A magnetically ballasted T12 fluorescent lamp has 28.4% flicker and a Flicker Index of 0.07.

[2] The 'A19' designation breaks down as follows: 'A' is the familiar pear shape with a narrow base. The '19' refers to the lamp diameter in eighths of an inch. An A19 lamp is therefore pear shape with $2\frac{3}{8}$ inches diameter.

REFERENCE

1. CL8800 Datasheet, "Sequential Linear LED Driver", DS20005357, Microchip Technology Inc., 2020.
2. CL88020 Datasheet, "Sequential Linear LED Driver with Four Taps", DS20005753, Microchip Technology Inc., 2020.
3. CL88030 Datasheet, "Sequential Linear LED Driver with Four or Six Taps", DS20006049, Microchip Technology Inc., 2020.
4. VN2460 Datasheet, "N-Channel Enhancement Mode Vertical DMOS FET", Microchip Technology Inc., 2020.
5. **LED Lamp Flicker paper sponsored by the DOE** [http://www.e3tnw.org/Documents/2011 IES flicker paper poplawski-miller-FINAL.pdf](http://www.e3tnw.org/Documents/2011%20IES%20flicker%20paper%20poplawski-miller-FINAL.pdf)
6. **Illuminating Engineering Society Of North America Lighting Handbook Flicker definitions.** Perform a Google search on "IESNA flicker" and review the images found
7. **Patent 8586651** Multiple Stage Sequential Current Regulator
8. **Patent 9575497** Current Control Circuit For Linear LED Driver

In this document, fair-use reference may be made to other companies and their products. Their copyrights, patents, and trademarks belong to them. No relationship between them and Microchip is expressed or implied.

Microchip has patents and other intellectual property rights on some concepts described here as well.

AN3444

NOTES:

Note the following details of the code protection feature on Microchip devices:

- Microchip products meet the specification contained in their particular Microchip Data Sheet.
- Microchip believes that its family of products is one of the most secure families of its kind on the market today, when used in the intended manner and under normal conditions.
- There are dishonest and possibly illegal methods used to breach the code protection feature. All of these methods, to our knowledge, require using the Microchip products in a manner outside the operating specifications contained in Microchip's Data Sheets. Most likely, the person doing so is engaged in theft of intellectual property.
- Microchip is willing to work with the customer who is concerned about the integrity of their code.
- Neither Microchip nor any other semiconductor manufacturer can guarantee the security of their code. Code protection does not mean that we are guaranteeing the product as “unbreakable.”

Code protection is constantly evolving. We at Microchip are committed to continuously improving the code protection features of our products. Attempts to break Microchip's code protection feature may be a violation of the Digital Millennium Copyright Act. If such acts allow unauthorized access to your software or other copyrighted work, you may have a right to sue for relief under that Act.

Information contained in this publication regarding device applications and the like is provided only for your convenience and may be superseded by updates. It is your responsibility to ensure that your application meets with your specifications. MICROCHIP MAKES NO REPRESENTATIONS OR WARRANTIES OF ANY KIND WHETHER EXPRESS OR IMPLIED, WRITTEN OR ORAL, STATUTORY OR OTHERWISE, RELATED TO THE INFORMATION, INCLUDING BUT NOT LIMITED TO ITS CONDITION, QUALITY, PERFORMANCE, MERCHANTABILITY OR FITNESS FOR PURPOSE. Microchip disclaims all liability arising from this information and its use. Use of Microchip devices in life support and/or safety applications is entirely at the buyer's risk, and the buyer agrees to defend, indemnify and hold harmless Microchip from any and all damages, claims, suits, or expenses resulting from such use. No licenses are conveyed, implicitly or otherwise, under any Microchip intellectual property rights unless otherwise stated.

Trademarks

The Microchip name and logo, the Microchip logo, Adaptec, AnyRate, AVR, AVR logo, AVR Freaks, BesTime, BitCloud, chipKIT, chipKIT logo, CryptoMemory, CryptoRF, dsPIC, FlashFlex, flexPWR, HELDO, IGLOO, JukeBlox, KeeLoq, Klear, LANCheck, LinkMD, maXStylus, maXTouch, MediaLB, megaAVR, Microsemi, Microsemi logo, MOST, MOST logo, MPLAB, OptoLyzer, PackeTime, PIC, picoPower, PICSTART, PIC32 logo, PolarFire, Prochip Designer, QTouch, SAM-BA, SenGenuity, SpyNIC, SST, SST Logo, SuperFlash, Symmetricom, SyncServer, Tachyon, TempTrackr, TimeSource, tinyAVR, UNI/O, Vectron, and XMEGA are registered trademarks of Microchip Technology Incorporated in the U.S.A. and other countries.

APT, ClockWorks, The Embedded Control Solutions Company, EtherSynch, FlashTec, Hyper Speed Control, HyperLight Load, IntelliMOS, Libero, motorBench, mTouch, Powermite 3, Precision Edge, ProASIC, ProASIC Plus, ProASIC Plus logo, Quiet-Wire, SmartFusion, SyncWorld, Temux, TimeCesium, TimeHub, TimePictra, TimeProvider, Vite, WinPath, and ZL are registered trademarks of Microchip Technology Incorporated in the U.S.A.

Adjacent Key Suppression, AKS, Analog-for-the-Digital Age, Any Capacitor, AnyIn, AnyOut, BlueSky, BodyCom, CodeGuard, CryptoAuthentication, CryptoAutomotive, CryptoCompanion, CryptoController, dsPICDEM, dsPICDEM.net, Dynamic Average Matching, DAM, ECAN, EtherGREEN, In-Circuit Serial Programming, ICSP, INICnet, Inter-Chip Connectivity, JitterBlocker, KlearNet, KlearNet logo, memBrain, Mindi, MiWi, MPASM, MPF, MPLAB Certified logo, MPLIB, MPLINK, MultiTRAK, NetDetach, Omniscient Code Generation, PICDEM, PICDEM.net, PICKit, PICtail, PowerSmart, PureSilicon, QMatrix, REAL ICE, Ripple Blocker, SAM-ICE, Serial Quad I/O, SMART-I.S., SQI, SuperSwitcher, SuperSwitcher II, Total Endurance, TSHARC, USBCheck, VariSense, ViewSpan, WiperLock, Wireless DNA, and ZENA are trademarks of Microchip Technology Incorporated in the U.S.A. and other countries.

SQTP is a service mark of Microchip Technology Incorporated in the U.S.A.

The Adaptec logo, Frequency on Demand, Silicon Storage Technology, and Symmcom are registered trademarks of Microchip Technology Inc. in other countries.

GestIC is a registered trademark of Microchip Technology Germany II GmbH & Co. KG, a subsidiary of Microchip Technology Inc., in other countries.

All other trademarks mentioned herein are property of their respective companies.

© 2020, Microchip Technology Incorporated, All Rights Reserved.

ISBN: 978-1-5224-5895-1

For information regarding Microchip's Quality Management Systems, please visit www.microchip.com/quality.



MICROCHIP

Worldwide Sales and Service

AMERICAS

Corporate Office
2355 West Chandler Blvd.
Chandler, AZ 85224-6199
Tel: 480-792-7200
Fax: 480-792-7277
Technical Support:
<http://www.microchip.com/support>
Web Address:
www.microchip.com

Atlanta

Duluth, GA
Tel: 678-957-9614
Fax: 678-957-1455

Austin, TX

Tel: 512-257-3370

Boston

Westborough, MA
Tel: 774-760-0087
Fax: 774-760-0088

Chicago

Itasca, IL
Tel: 630-285-0071
Fax: 630-285-0075

Dallas

Addison, TX
Tel: 972-818-7423
Fax: 972-818-2924

Detroit

Novi, MI
Tel: 248-848-4000

Houston, TX

Tel: 281-894-5983

Indianapolis

Noblesville, IN
Tel: 317-773-8323
Fax: 317-773-5453
Tel: 317-536-2380

Los Angeles

Mission Viejo, CA
Tel: 949-462-9523
Fax: 949-462-9608
Tel: 951-273-7800

Raleigh, NC

Tel: 919-844-7510

New York, NY

Tel: 631-435-6000

San Jose, CA

Tel: 408-735-9110
Tel: 408-436-4270

Canada - Toronto

Tel: 905-695-1980
Fax: 905-695-2078

ASIA/PACIFIC

Australia - Sydney
Tel: 61-2-9868-6733

China - Beijing
Tel: 86-10-8569-7000

China - Chengdu
Tel: 86-28-8665-5511

China - Chongqing
Tel: 86-23-8980-9588

China - Dongguan
Tel: 86-769-8702-9880

China - Guangzhou
Tel: 86-20-8755-8029

China - Hangzhou
Tel: 86-571-8792-8115

China - Hong Kong SAR
Tel: 852-2943-5100

China - Nanjing
Tel: 86-25-8473-2460

China - Qingdao
Tel: 86-532-8502-7355

China - Shanghai
Tel: 86-21-3326-8000

China - Shenyang
Tel: 86-24-2334-2829

China - Shenzhen
Tel: 86-755-8864-2200

China - Suzhou
Tel: 86-186-6233-1526

China - Wuhan
Tel: 86-27-5980-5300

China - Xian
Tel: 86-29-8833-7252

China - Xiamen
Tel: 86-592-2388138

China - Zhuhai
Tel: 86-756-3210040

ASIA/PACIFIC

India - Bangalore
Tel: 91-80-3090-4444

India - New Delhi
Tel: 91-11-4160-8631

India - Pune
Tel: 91-20-4121-0141

Japan - Osaka
Tel: 81-6-6152-7160

Japan - Tokyo
Tel: 81-3-6880-3770

Korea - Daegu
Tel: 82-53-744-4301

Korea - Seoul
Tel: 82-2-554-7200

Malaysia - Kuala Lumpur
Tel: 60-3-7651-7906

Malaysia - Penang
Tel: 60-4-227-8870

Philippines - Manila
Tel: 63-2-634-9065

Singapore
Tel: 65-6334-8870

Taiwan - Hsin Chu
Tel: 886-3-577-8366

Taiwan - Kaohsiung
Tel: 886-7-213-7830

Taiwan - Taipei
Tel: 886-2-2508-8600

Thailand - Bangkok
Tel: 66-2-694-1351

Vietnam - Ho Chi Minh
Tel: 84-28-5448-2100

EUROPE

Austria - Wels
Tel: 43-7242-2244-39
Fax: 43-7242-2244-393

Denmark - Copenhagen
Tel: 45-4485-5910
Fax: 45-4485-2829

Finland - Espoo
Tel: 358-9-4520-820

France - Paris
Tel: 33-1-69-53-63-20
Fax: 33-1-69-30-90-79

Germany - Garching
Tel: 49-8931-9700

Germany - Haan
Tel: 49-2129-3766400

Germany - Heilbronn
Tel: 49-7131-72400

Germany - Karlsruhe
Tel: 49-721-625370

Germany - Munich
Tel: 49-89-627-144-0
Fax: 49-89-627-144-44

Germany - Rosenheim
Tel: 49-8031-354-560

Israel - Ra'anana
Tel: 972-9-744-7705

Italy - Milan
Tel: 39-0331-742611
Fax: 39-0331-466781

Italy - Padova
Tel: 39-049-7625286

Netherlands - Drunen
Tel: 31-416-690399
Fax: 31-416-690340

Norway - Trondheim
Tel: 47-7288-4388

Poland - Warsaw
Tel: 48-22-3325737

Romania - Bucharest
Tel: 40-21-407-87-50

Spain - Madrid
Tel: 34-91-708-08-90
Fax: 34-91-708-08-91

Sweden - Gothenberg
Tel: 46-31-704-60-40

Sweden - Stockholm
Tel: 46-8-5090-4654

UK - Wokingham
Tel: 44-118-921-5800
Fax: 44-118-921-5820